

AGENDA ITEM NO. 13

Council

Date **12 May 2016**

Title **Revised Hackney Carriage and Private Hire Licensing Policy.**

1) PURPOSE/SUMMARY

To adopt the revised Hackney Carriage and Private Hire Licensing Policy.

2. KEY ISSUES

- The current taxi and private hire licensing policy was approved by Full Council on 15 December 2011. Changes under the Deregulation Act 2015 and the Immigration Bill 2015 prompted a review of our current policy.
- The Local Government Association encourages best practice in the adoption of a formal statement of policy for relevant convictions.
- It is best practice to publish a policy which sets out our general approach to regulation and enforcement activities in relation to taxi and private hire services to maintain a consistent approach, build public confidence and assist in supporting business.
- Licensing Committee met on the 15th January 2016 to consider a proposed Hackney Carriage and Private Hire Licensing Policy to be sent out to consultation with the community, partners and trade.
- Public consultation took place from 10 February 2016 to 7 April 2016
- Two meetings with the taxi trade took place within the consultation period on 24 February 2016 and the 2 March 2016.
- Licensing Committee met again on 19 April 2016 to review and consider responses received to the proposed Hackney Carriage and Private Hire Licensing Policy and agree any amendments.

3. RECOMMENDATION TO LICENSING COMMITTEE

- That Full Council adopt the revised Hackney Carriage and Private Hire Licensing Policy

Wards Affected	All
Forward Plan Reference No. (if applicable)	Not applicable
Portfolio Holder(s)	Councillor David Oliver, Portfolio Holder for Community Safety and Heritage
Report Originator	Kim Winterton, Licensing Manager, tel: 01354 622542, email: kwinterton@fenland.gov.uk

Contact Officer(s)	Kim Winterton (as above) Dan Horn, Head of Housing & Community Support, 01354 654321, dhorn@fenland.gov.uk Richard Cassidy, Corporate Director, 01354 622300, richardcassidy@fenland.gov.uk .
Background Papers	Part II of the Local Government (Miscellaneous Provisions) Act 1976 Town Police Clauses Act 1847 Department of Transport – Taxi and Private Hire Vehicle Licensing : Best Practice Guidance LGA Taxi and PHV licensing Councillors' Handbook

1 BACKGROUND

- 1.1 The licences administered by the Council under the above legislation are:
- Hackney Carriage Proprietors Licence
 - Hackney Carriage Drivers Licence
 - Private Hire Vehicle Proprietors Licence
 - Private Hire Drivers Licence
 - Private Hire Operators Licence.
- 1.2 The current policy was adopted by the Council in 2011 and the proposed revised Statement of Licensing Policy is at **Appendix A** to this report.
- 1.3 Public consultation took place from 10 February 2016 until the 7 April 2016.
- 1.4 During the consultation period, officers met with members of the taxi trade on two occasions, the 24 February 2016 and the 2 March 2016.
- 1.5 Licensing Committee members discussed and reviewed responses on the following changes to the policy document:

Policy No.	Proposal	Discussed and agreed
3.6	Dual Drivers Licence (Third type of licence offered)	To add resilience to the trade of small businesses operating within Fenland. Agreed.
3.11	Wheelchair Accessible Vehicles (WAV) – all Hackney Carriage vehicles to be WAV after a specific licence plate number thereby ensuring a mix of saloon and WAV types.	To facilitate provision for service users – Option B to go forward: Any new application for a hackney carriage vehicle licence must be submitted with a vehicle that is wheelchair accessible. Renewal applications may continue to licence saloon/people carrier type vehicles at the time of vehicle replacement. Agreed -To be reviewed in one year.
3.14	Convictions Policy – new document to be added to advise Licensing committee members sitting on licensing panel.	To provide for an updated and informed decision making tool for members. Agreed.
4.8	Right to Work Checks – new legislative requirement.	New legislation measures to ensure those applying for licences have a right to work in this country. Agreed.
4.20	Knowledge Test for new drivers	Identified required skill set for licensed

	to include numeracy test – skills required in the course of work as a licensed driver.	drivers. Agreed.
5.26	Vehicles over 5 years will require 6 monthly vehicle checks – wear and tear on vehicles addressed.	To identify and correct issues by early intervention process. Agreed – to be reviewed in one year.
5.38	ID tags on fire extinguisher equipment – to prevent exchanges between vehicles for test purposes only.	Problem issue identified. Agreed.
5.63	Internal Licence Plates for display on windscreen – to assist passengers with licence information.	To provide passenger information on licensed vehicle for public safety reasons. Agreed
6.30	Responsibilities for Meter including calibration – to reiterate responsibilities of vehicle proprietors.	To provide information and guidance for vehicle proprietors on their responsibility for the meter provision and calibration certificate checks. Agreed
	Addition of the Special event vehicle policy to the main policy document.	Administration purposes only. Agreed
9.20	Drivers to notify of convictions/summons/CCJ – The council require all information available to order to determine licence applications.	To allow for an informed decision on licence applications. Agreed.
	Penalty points scheme	To provide a light touch approach to compliance and enforcement. Agreed
	Safeguarding Training	To provide information, guidance and advice on an emotive, sensitive and serious topic that is impacting the trade across the country. Agreed.

2 LEGAL IMPLICATIONS

- 2.1 The Council is the licensing authority for the purposes of taxi and private hire licensing under the Local Government (Miscellaneous Provisions) Act 1976 and the Town Police Clauses Act 1867.
- 2.2 Neither Act requires the Council to prepare a taxi and private hire licensing policy. However, it is best practice to prepare a policy which contains the principles that it proposes to apply in exercising its functions.

3 COMMUNITY

- 3.1 The overall aim of the policy is to provide a system of local control which is intended to protect public safety and ensure there is accessibility for all users of taxis and private hire vehicles.

4 CONCLUSION

- 4.1 That Council adopt the Hackney Carriage and Private Hire Licensing Policy as recommended by Licensing Committee on 19 April 2016

Link to relevant documents presented at Licensing Committee on 19 April 2016:
<http://www.fenland.gov.uk/egenda/kab71.pl?cmte=LIC>

FENLAND DISTRICT COUNCIL

**STATEMENT OF
HACKNEY CARRIAGE & PRIVATE HIRE
LICENSING POLICY & CONDITIONS**

Approved by Full Council: 12 May 2016

INDEX

1.0	Introduction	3
2.0	General Statement of Licensing	3
3.0	Role of the Licensing Authority	6
4.0	Application Process	10
5.0	All Vehicles	20
6.0	Hackney Carriage Vehicles	30
7.0	Private Hire Vehicles	36
8.0	Special Event Vehicles	38
9.0	Drivers Licences (Including Dual licence)	39
10.0	Operator Licensing	49
11.0	Enforcement	54
	Appendix 1- Hackney Carriage Byelaws	57
	Appendix 2- Penalty Points System	63
	Appendix 3- Summary Of Offences	66
	Appendix 4 – Relevance of Convictions	70
	Appendix 5 – Vehicle Compliance Test Standard	80
	Appendix 6–Map of Fenland District Council Boundary	93

1.0 Introduction - Fenland's Profile

- 1.1 Fenland District Council is situated in the County of Cambridgeshire, which comprises five District and City Councils and one Unitary authority.
- 1.2 The Council has a population of approximately, 96,252 and covers an area of 54,547 hectares and is situated in the north-east of Cambridgeshire between the larger and contrasting centres of Cambridge, Peterborough, King's Lynn and Huntingdon. The main centres of population in Fenland are in the market towns of Chatteris, March, Whittlesey and Wisbech.
- 1.3 The area is predominantly rural in character comprising four market towns plus a number of villages and hamlets. It has a population of approximately 97,000 people.
- 1.4 The Fenland District offers a wide and developing variety of culture, history, businesses, recreation and dwellings with transport infrastructure provided by the mainline railway to London, Peterborough, Cambridge and Stansted Airport, local bus services and established Hackney Carriage and Private Hire trades.
- 1.5 This Statement of Licensing Policy has been offered for consultation in accordance with Part II of the Local Government (Miscellaneous Provisions) Act 1976.
- 1.6 Having been approved by full Council on **12 May 2016** it will have effect from **XXXX**

2.0 General Statement of Licensing

- 2.1 Fenland District Council licences the following:
 - Hackney Carriage Proprietors
 - Private Hire Proprietors
 - Private Hire Operators
 - Hackney Carriage and Private Hire Vehicle Drivers.
- 2.2 The authority for doing so was the adoption of Part II of the Local Government (Miscellaneous Provisions) Act 1976, the Town Police Clauses Act 1847 and the Public Health Act 1875.
- 2.3 This document is intended to advise and assist applicants and licence holders on the law relating to the operation of Hackney Carriage and Private Hire Vehicles and operators.
- 2.4 It is not a definitive statement of the law relating to Hackney Carriage and Private Hire Licensing, and therefore should not be considered as such.
- 2.5 It should also be noted that whilst every effort is made to ensure the accuracy of this guidance document Fenland District Council cannot be held responsible for any inaccuracies. Please note that conditions, fees, etc. are subject to change at any time.

- 2.6 In producing this document, Fenland District Council wishes to demonstrate its commitment to ensuring that the Hackney Carriage and Private Hire trades maintain the highest possible standards.
- 2.7 In adopting the licensing conditions set out in this document the Licensing Authority aims to ensure public confidence in a safe and high quality service, which presents a professional and positive image to both residents and visitors to the town.
- 2.8 The licence conditions associated with this document are designed to ensure that these objectives are met. The conditions will be applied fairly and uniformly throughout the trade. The Licensing Authority expects operators, vehicle proprietors and drivers to co-operate fully to ensure the highest standards are maintained, as the safety of the public and the image presented by the trade will always remain the primary consideration for Fenland District Council.
- 2.9 Any requirements of legislation that affect the operations being carried out under the terms of any licence granted should be regarded as if they are conditions of that licence. Wherever there appears in this document a summary of any statutory provisions, the statute will prevail.
- 2.10 Details held by the Licensing Authority about drivers, vehicles or operators may be passed to partner agencies for data matching for the prevention of crime and detection within the spirit of the Data Protection Act.
- 2.11 Fenland District Council wholeheartedly supports the principle of equality of opportunity in employment and service delivery and opposes all forms of discrimination on the grounds of the protected characteristics of the Equalities Act 2010.
- 2.12 Fenland District Council welcomes and encourages applications from all sectors of society to be involved with the licensed trade.
- 2.13 This document will be reviewed on a regular basis and minor changes will be made following consultation with the Hackney Carriage and Private Hire Trades, as and when deemed necessary.
- 2.14 This document is made after consultation with:
 - a. Cambridgeshire Constabulary
 - b. Local disability interest groups
 - c. Hackney Carriage drivers
 - d. Private Hire drivers
 - e. Private Hire operators
 - f. Hackney Carriage/Private Hire vehicle proprietors
 - g. Bodies representing users of the service
 - h. Fenland District Council Services (e.g. Planning, Highways, Parking Enforcement)
 - i. the general public

3.0 The Role of the Licensing Authority

- 3.1 The District Council acting as the Licensing Authority is responsible for the licensing of all hire vehicles which operate within the district which are provide with a driver and operated with less than nine passenger seats.
- 3.2 There are two types of vehicle: public hire vehicles (Hackney Carriages) and vehicles which are only available by prior booking arrangement (Private Hire). Although the description 'taxi' should only be applied to a hackney carriage any hire vehicle is usually known as a 'taxi' by the public.
- 3.3 Before any vehicle is licensed it must be tested at the District Council garage. The test covers the vehicle's mechanics and general appearance, which includes the comfort for passengers and the reliability of any meter fitted.
- 3.4 Private Hire vehicles may only undertake journeys in response to advance bookings. The District Council is responsible for granting private hire operators licences for the premises at which these bookings are made.
- 3.5 The District Council is responsible for licensing drivers of both classes of vehicle to work within Fenland. It recognises that a driver is in a position of trust for all passengers and therefore expects high standards from its drivers. Within the scope of legislation the District Council ensures that all drivers are 'fit and proper' persons to be licensed by carrying out checks on an applicant's background.
- 3.6 The District Council issue dual driver's licences to all successful applicants, which enables the holder to drive either a hackney carriage vehicle or a private hire vehicle provided that these vehicles are licensed by this authority.
- 3.7 As part of ensuring drivers are suitable for the job, the District Council carries out enhanced Disclosure and Barring Service checks. For more information visit the Disclosure and Barring Service (DBS) website at www.gov.uk/government/.../disclosure-and-barring-service
- 3.8 The District Council also has a responsibility as the 'Enforcement Agency' of the drivers, vehicles and operators it has licensed. Enforcement covers offences related to 'taxi' legislation, driver's behaviour, the condition of the vehicles and the investigation of complaints made against any licence holder.
- 3.9 As well as granting and issuing licences the District Council also has the power to suspend or revoke licences and take Court action if necessary against any offending licence holder.
- 3.10 Licensing and enforcement is carried out by District Council Officers appointed 'Authorised Officers' for that purpose and they have been issued with written authority to do so as well as having a District Council identity badge.

Wheelchair Accessible Hire Vehicles

- 3.11 There are a number of wheelchair accessible vehicles available in Fenland which are licensed by the District Council. Any new application for a hackney carriage vehicle licence must be submitted with a vehicle that is wheelchair accessible. In regard to renewal applications the applicant may continue to licence saloon/people carrier type vehicles with an existing plate number at the time of a vehicle replacement.
- 3.12 The District Council welcomes views and information from the public regarding their needs for wheelchair accessible vehicles, the availability of currently licensed vehicles or what would help to provide an efficient 'taxi' service for people with physical disabilities.

Hackney Carriage /Private Hire Drivers Licences

- 3.13 In considering new applications for Hackney Carriage /Private Hire Drivers Licences and also any breaches during the currency of a licence, the District Council must be satisfied that drivers are fit and proper persons to hold a licence.
- 3.14 In doing so, they must have regard to all convictions, police cautions, charges, driving convictions, complaints of unacceptable conduct/ behaviour, breach of licence conditions and other convictions obtained during the course of a licence, in accordance with the convictions policy.
- 3.15 When such circumstances occur the application may be referred to a Panel of the Licensing Committee for determination.

Referral to Panel of Licensing.

- 3.16 Where an applicant or a driver is referred to the Panel for consideration, they will be notified in writing of the reason and the date, time and venue of the Panel Hearing.
- 3.17 They will be advised that they may bring a representative to the hearing. The representative may be a friend, legal representative or a representative from the trade whom they wish to assist them in addressing the Panel in support of their applicant/disciplinary hearing. But please note that any consultation with a representative should take place in advance of the hearing date and not just prior to the meeting. This will ensure that their case is well prepared for Panel consideration.

The Licensing Panel

- 3.18 The Panel will consist of members made up of District Councillors. A Chairman is appointed to supervise the Committee during the process. The Committee may be advised by a legal representative.
- 3.19 A number of District Council officers may also attend the hearing, in an advisory capacity. However, they do not take part in the decision making process.

The Hearing

- 3.20 A number of applications and disciplinary matters could be considered on the day, including any historic matters. Each matter will be considered on its own

merits and the public will be excluded to protect confidentiality where appropriate. In these circumstances the public will not have access to the meeting unless the applicant requests that they should.

- 3.21 When a person is called to appear before the Panel they and their representative and any complainants will be guided to their seats. They will be asked if they have received a copy of the report regarding the circumstances surrounding their case. The Panel will already have a copy of the report. Where the case arises from a complaint, the complainant, if present, will be asked to explain their complaint to the Panel. They will then be given the opportunity to question the complainant.
- 3.22 They will be asked to describe the circumstances surrounding the convictions or incident concerned and asked to demonstrate to the Panel why they think they are a fit and proper person to hold a Hackney Carriage/Private Hire Drivers Licence or why they feel disciplinary action should not be taken.

The Decision

- 3.23 When considering convictions, the Panel will have regard to the 'Guidance relating to the relevance of convictions and cautions' a copy of which is attached in Annexe section of this policy.
- 3.24 After hearing the evidence and representations from all parties, the Panel will retire to make their decision.
- 3.25 As soon as the Panel have come to a decision they will return to the room and inform the persons of their decision. The person will also be advised of the decision in writing together with their rights of appeal. The Panel have a number of options which include the following:-
- Grant or refuse the application
 - Take no action
 - Issue a verbal warning
 - Suspend or revoke the licence
 - Apply conditions to the licence
 - Require driver to complete DVSA and/or sit the Council's Knowledge test, or any other action deemed appropriate.

Right of Appeal

- 3.26 If the District Council refuses the grant of a Vehicle, Operator or Drivers Licence, or in the case of a disciplinary hearing, decide to suspend or revoke a Drivers Licence or any other formal action, the person will have the right of appeal to a Magistrates' Court. In the case of refusal to grant a Hackney Carriage Proprietors Licence, appeal will be to the Crown Court.

General Advice

- 3.27 The Licensing Panel is a formal meeting where members sit in a quasi-judicial manner. This means that the Panel has to act in a similar fashion to a Court or Tribunal. It is therefore important that persons appearing before Committee should behave and dress in an appropriate manner.

- 3.28 If a person appears before the Panel following a complaint about their conduct, they should not attempt to speak to the complainants/witnesses prior to the meeting as this could be deemed to be harassment.

Serving of Notices

- 3.29 Sub-sections (2) to (5) of S23 of the Local Government Act 1972 shall have effect and are incorporated in the conditions for vehicles, operators and drivers in relation to any notices required or authorised by the conditions to be given or served on the licensee by or on behalf of the District Council or any authorised officer.

4.0 Application Process

Driver Application

- 4.1 In addition to the application form, all applications for driver licences must be accompanied by the following:
1. Disclosure and Barring Service certificate (DBS) and unique electronic number;
 2. Driver's Group II Medical;
 3. DVLA Driving Licence – (photocard or paper licence)
 4. DVLA Mandate
 5. Correct Fees applicable;
 6. Passport Size Photograph certified as being a true likeness;
 7. Driver Vehicle Standards Agency (DVSA) Hackney Carriage/Private Hire Test Assessment Pass Certificate.

Disclosure and Barring Service form (DBS) & Right to Work Check

- 4.2 As part of the application process, the Applicant will obtain (with the applicants consent) a Disclosure and Barring Service check to 'enhanced' standard. The District Council are no longer a registered body to process DBS applications The DBS process takes can take up to 8 weeks. Applicants that already have a disclosure and have signed up to the online update service must provide the most recent original disclosure certificate and the unique online reference number so the Council may access their record online.
- 4.3 You will be required to provide us with a new Disclosure and Barring Service check every 3 years unless your licence expires beforehand,
- 4.4 The original disclosure document must be produced to Fenland Council's Licensing Team. A disclosure with no convictions will be processed; the disclosure number recorded and the date of issue will be entered onto our computer system. A Disclosure with conviction/s may not necessarily mean that you are not a "fit and proper" person to hold a licence. Fenland Council officers only have delegated powers to deal with certain convictions. Depending on the type and age of conviction we may offer you a licence, refuse a licence under delegated powers or we may refer you to a Licensing Panel to determine whether you are a "fit and proper" person.

- 4.5 If an applicant has been resident in any other Country than the UK, preceding an application, a certificate of good conduct from an overseas embassy, or each overseas embassy where the applicant has lived, will be required in addition to the Disclosure and Barring Service Disclosure.
- 4.6 Information revealed on a DBS Disclosure will only be used for the purpose of determining an application in relation to hackney carriage or private hire licensing.
- 4.7 Fenland Council will retain a copy of the Disclosure and Barring Service Disclosure. The information contained on the original Disclosure is required for Fenland Council to complete a check with those subscribed to the DBS online update service.

Right to Work Check

- 4.8 All applicants must provide documentation to prove that they have the right to work in the United Kingdom. A 'Right to work Checklist' providing a list of valid documentation can be found on the Home Office website. An application from a person who cannot provide the necessary documentation will be refused by officers under delegated authority.

Driving Standards Agency Certificate of Assessment

- 4.9 All new applicants will be required to take and pass a driving ability test with the Driving Standards Agency.
- 4.10 Contact should be made with the Driving Standards Agency; they will arrange a date for the assessment. Each applicant should read the information carefully before arranging and paying for the test. The test will take place using the applicant's vehicle, apart from in exceptional circumstances. The vehicles must, however, be roadworthy – the Assessor will not do the test if the vehicle appears not to be and the test fee will be lost.
- 4.11 The assessment should be regarded as a helpful exercise where minor faults by the applicant will be corrected given the time available. If the fault persists during the test, however, it may be considered sufficient to fail the applicant. The Assessment criteria are set out in the DVSA Handbook.
- 4.12 If the test is passed, the applicant will be issued with a certificate, which should be presented as part of your subsequent application. The Council will also receive a report on each test taken, whether passed or failed.
- 4.13 If applicants fail the test, if they wish, they may retake it as soon as it can be arranged. If they fail the test three times the application may be refused.

Driver's Medical

- 4.14 A medical will be required upon initial application and must be carried out by your registered Medical Practitioner. It is the Council's policy that all drivers undertake a medical examination to ensure their fitness to drive.

- 4.15 The standards required are as laid down in the DVLA publication 'At a Glance Guide to the Current Medical Standards of Fitness to Drive'. The standard required is the 'Group 2 Entitlement'.
- 4.16 Your doctor must complete the medical form. A subsequent medical will be required at age 45 then every five years after the age of 45 and then annually from the age of 65 years. A driver under the age of 65 with a controlled medical condition may also be required to undergo a full medical annually.

DVLA Driving Licence & Mandate

- 4.17 Applicants will need to supply the DVLA driving licence with their current address. Holders of Photo-card only driving licences are required to supply the photo card and holders of paper licences are required to provide their paper part of the licence. There is a DVLA mandate form that must be completed and signed. This will be sent to the DVLA to obtain the driving licence history. This process takes an average of two weeks. The DVLA advises on the status of the applicant's current UK driving licence and discloses traffic offences, which might not appear on the CRB disclosure.

Rehabilitation of Offenders Act 1988

- 4.18 Applicants for taxi and private hire licensing are exempt from the Rehabilitation of Offenders Act 1988. Therefore all convictions, regardless of how long ago may be taken in consideration when determining applications. However, in the determining the relevance of convictions the Panel will take into account the type of offence, the age of the applicant at the time of the offence and the apparent seriousness of the offence.

Passport Style Colour Photographs

- 4.19 For new applicants, one recent, colour photograph of the applicant must accompany the application for the grant of a drivers licence and shall be:
- Taken against a light background so that the applicant's features are distinguishable and contrast against the background.
 - 45 millimetres tall by 35 millimetres wide.
 - Full face uncovered and without sunglasses and, unless the applicant wears a head covering due to his/her religious beliefs, without a head covering.
 - On photographic paper.
- 4.20 New applicants will also be required to take and pass a local knowledge test as part of the application process prior to obtaining a licence. The test will include multi-choice questions on Licensing Conditions, Highway Code, knowledge of the area, literacy and numeracy and will be conducted by Officers at the District Council. Further information may be obtained from the Licensing team.

- 4.21 This policy introduces mandatory safeguarding training for all drivers wishing to obtain or retain their licences. Drivers will be required to produce a pass certificate to the Licensing Authority confirming that they have undertaken and completed a training session on safeguarding and safer recruitment. Course dates and booking information will be provided to drivers as part of the licensing process.

Fees

- 4.21 Applications with all the relevant supporting documentation will not be accepted without the appropriate fee. Payment by either cash or debit card is acceptable. Any licence in respect of which the licence fee has been paid by cheque shall not be effective until the cheque has been cleared.
- 4.22 An application is deemed to be incomplete if one or more of the necessary documents or payment is not submitted with the application
- 4.23 If all the above information is satisfactory, a licence will be issued together with an identification badge which must be worn by the driver at all times on the lanyard provided where it can be seen by passengers.
- 4.24 **Please Note:** Should an applicant have 7 (seven) or more points on the DVLA driving licence and or any previous convictions then their application will be referred to a Licensing Panel hearing to ascertain whether the applicant is a 'fit and proper person' to hold a licence.

Renewal Application - Existing Drivers Licence

- 4.25 An existing driver **must** submit a renewal application before the expiry of the existing licence. If the licence has been allowed to lapse we will not be able to renew it, and the driver will have to begin the whole application procedure again as a new applicant, which will include the requirement to take the DVSA driving test.

Renewal applications will include:-

- 4.26
- A complete relevant application form (Any application for a Private Hire or Hackney Carriage drivers licence is exempt from the Rehabilitation of Offenders Act by virtue of the 2002 amendment s75. An applicant is therefore required to declare any pending prosecutions or convictions they may have, irrespective of their age, and should also declare any cautions or bind-over)
 - the relevant fee (see point 4.21 for Fees)
 - an original DVLA driver's licence.
- 4.27 There will be times when the following may apply (normally every 3rd year) and should that be the case the following will also be required:
- A Disclosure and Barring Service (DBS) update - to allow a search to be carried out for previous non-motoring convictions. **NB:** If any convictions arise

during the term of the licence the Licensing Team at Fenland District Council must be informed in writing within seven days from the date of conviction.

- A DVLA Mandate - to provide written permission for the Council to undertake a check with the Driver and Vehicle Licensing Authority at Swansea.
 - A Medical report - Medicals are required for all new applicants and another medical is not required until age 45, after which, a five year interval carries on until 65, and then an annual medical is required.
- 4.28 If all the information above is satisfactory, a licence will be issued together with an identification badge which must be worn by the driver at all times on the lanyard provided where it can be seen by passengers.
- 4.29 **Please Note:** Should an applicant have 7 (seven) or more points on the DVLA driving licence and or any previous convictions then their application will be referred to a Licensing Panel hearing to ascertain whether the applicant is a 'fit and proper person' to hold a licence.

Operators Application

- 4.31 Any person who receives bookings or has contracts for the hire and reward for a private hire vehicle is required to hold an operator's licence. The application must be accompanied with a list of vehicles and drivers used by the operator. An operator must be a 'fit and proper person' and is therefore subject to a DBS check.

Vehicle Applications

- 4.32 **Vehicle Inspection-** All vehicles licensed by this Authority require a compliance test at Fenland District Council's vehicle testing centre. The compliance test is carried out in addition to a vehicle MOT and covers the vehicle's mechanics and general appearance both inside and outside, vehicle livery, signage and advertising and the fitting of illuminated roof signs, licensing plates and the reliability of the taximeter fitted.
- 4.33 A vehicle application will be processed within 5 working days if all the relevant information has been supplied as below and the vehicle meets current conditions.
- Registration Document or Bill of Sale – The applicant will need to prove that they are the owner of the vehicle by providing an original copy of the vehicles VQ5 (vehicle document), or the New Keepers supplement from the VQ5, or a bill of sale for that vehicle pending VQ5 documentation. However, the VQ5 documentation must be submitted within 6 weeks of the original documentation submission.
 - Insurance Certificate – Where a vehicle is not currently plated, evidence of insurance for use on the road must be provided with the application. No licence will however be granted until such time as full policy documentation has been provided.
 - Vehicle Inspection/MOT – Prior to issue or renewal of a licence, all vehicles must be mechanically inspected at the Council's vehicle testing centre.

Before an applicant takes a vehicle for inspection they must ensure it is roadworthy and it complies with all of the Council's vehicle conditions, which are listed under the relevant licence applied for.

- All vehicles must pass the Council's compliance test for a Certificate of Compliance (no more than one calendar month old when presented for licensing) before issue or renewal.
- MOT certificates are to be dated **no more than one calendar month old** prior to vehicle inspection.
- NB: It is a Ministry of Transport requirement under the Road Traffic Act, 1988 (S47), for all vehicles used for Hackney Carriage purposes to possess a full MOT certificate once the vehicle has reached one year of age and annually thereafter.
- Payment of the relevant fee's.

4.34 Renewal vehicle plates must be obtained prior to the expiry of any existing licence and will only be issued upon production of the existing plates.

4.35 Vehicle renewal applications will be accepted up to one calendar month before they are due to expire providing the MOT certificate is no more than one calendar month older than the renewal date. Vehicle licences will not be granted an earlier renewal date than their current expiry date. Vehicle Registration documents (V5C) are not required to be produced upon renewal of a vehicle licence, providing there has been no material changes to that vehicle/document during the preceding licence period.

Dual Driver Licence & Private Hire Operator

4.36 Dual Driver Licence renewals will be accepted up to one calendar month before they are due to expire.

4.37 NB:- Other than insurance documents sent by email or fax direct from the insurance company all documentation must be originals. Photocopies, scanned or fax copy in other circumstances is not acceptable under any circumstances

Refund of Licence Fees – (not relevant for Insurance/lease vehicles)

4.38 In the event that a driver's, vehicle or operator licence is not granted then the District Council will refund the licence fee. This does not however apply to the fees paid to, DBS, Medical, or for the Knowledge test.

4.40 Should a driver's, vehicle or operator licence be surrendered during the life of the licence then a pro-rata refund will be given for the unexpired portion of the licence. The date will be calculated from the date the licence is returned to the District Council. Refunds will not be given for licences that are revoked.

Death of Licence Holder

4.41 A licence will immediately lapse in the event of death of the licence holder. In the case of a vehicle licence, a licence may be transferred using the normal

procedure within 28 days. A private hire operator licence may not be transferred into another person's name.

5.0 All Vehicles

- 5.1 The District Council will not grant or renew a licence unless satisfied that the vehicle is suitable to be a licensed vehicle, is in a suitable mechanical condition, safe and comfortable.

Duration of a Licence

- 5.2 A vehicle licence, once granted, will be issued for a maximum period of one year, except in the case of a vehicle insurance replacement; see condition 5.4.

Vehicle Replacement

- 5.3 Where a vehicle is off the road due to accident damage, subject to satisfactory documentary evidence being produced to the authorised officer, the District Council may allow a replacement vehicle that meets the District Council's criteria for a hackney carriage/private hire vehicle.
- 5.4 The vehicle will be licensed as a replacement for the accident damaged vehicle for a period not exceeding 3 months. A 50% reduction to the normal application fee and a full licence plate fee will be required.
- 5.5 Whilst being repaired, the vehicle licence will be temporarily suspended and the licence plate must be returned to the authority. Once repaired, a new vehicle inspection report may be required and the suspended licence may be re-instated.

Insurance

- 5.6 A vehicle must have a current certificate of insurance or cover note which clearly covers the use to which the vehicle is to be put.
- 5.7 It shall be the responsibility of the proprietor of a licensed vehicle to produce proof of continuous insurance cover. The insurance proof is to be reviewed by the licensing authority within seven days of the expiry of the preceding certificate or cover note.
- 5.8 If the proprietor fails to produce a certificate of insurance cover on request he shall produce it forthwith or within seven clear days of the request to an authorised officer of the District Council. Failure to comply may result in the immediate suspension of the vehicle licence by authorised officers using delegated authority. The suspension will remain in place until a satisfactory certificate of insurance is produced.

Excise Licence (Road Tax) & Vehicle Registration Document (V5)

- 5.9 There should be a valid excise licence for the vehicle.
- 5.10 A full vehicle registration document must be produced at the grant of a licence, or as soon as is reasonable - and following any change to the original document.

Vehicle Specifications

- 5.11 The vehicle shall have four side opening doors (designed for the purpose of permitting persons access to/from the interior) – any lift-up tailgate shall not be included; or a vehicle shall have three side opening doors (designed for the purpose of permitting persons access to/from the interior) and two rear opening doors (designed for the purpose of permitting persons access to/from the interior). London type purpose built cabs would be acceptable for Hackney Carriage.
- 5.12 Any vehicle's suitability for licensing will also be determined by the position of its seating, fittings and fixtures for the access and egress of passengers and their safety.
- 5.13 Other than a vehicle classed as a special event vehicle, the vehicle must be right-hand drive.
- 5.14 The vehicle must have European Community Whole Vehicle Type Approval (ECWVTA) and must show category M1 on the V5C/logbook.
- 5.15 If the requirements in Condition 5.14 above cannot be satisfied, or if the vehicle has been altered from the original manufacturer's specification, then a Driver and Vehicle Standards Agency (DVSA) Individual Vehicle Approval (IVA) or Voluntary Individual Vehicle Approval (VIVA) inspection must be undertaken and a satisfactory report produced.
- 5.16 In the case of a Private Hire vehicle its appearance must not lead people to believe it is a Hackney Carriage Vehicle.
- 5.17 No vehicle will be licensed unless it can accommodate at least four passengers unless it holds an exemption.
- 5.18 This Council has agreed an exemption for Private Hire vehicles to include car vehicles that have seating for just one passenger and an engine not exceeding 800cc (i.e. similar to Smart Cars etc.)
- 5.19 The vehicle must have seats with a minimum width of not less than 400mm per person.
- 5.20 The vehicle shall be fitted with appropriate seatbelts to the front and rear seats of the vehicle.
- 5.21 All wheelchair accessible vehicles shall be properly equipped with properly mounted fittings for the safe securing of a wheelchair and a passenger seated in it, when carried in the vehicle.
- 5.22 If a mechanical hoist is fitted to the vehicle this will be required to be inspected annually by the manufacturer or his approved agent and a certificate produced to that effect.
- 5.23 Estate versions of saloon vehicles fitted with seats in the rear luggage compartment will be licensed for a maximum of 4 passengers.

Roof /Boot Racks & Bull bars

- 5.24 No roof, boot racks or bull bars may be fitted to licensed vehicles during the currency of the licence.

Carriage of Portable Oxygen Tanks

- 5.25 Licensed vehicle drivers will accept the carriage of portable oxygen tanks for passengers that require their usage for medical purposes. Precautions to be taken include:

- The oxygen cylinder should be secured into the boot of the car (but not left there for long periods) However, where it is needed for use during the journey this may not be possible.
- To prevent the cylinder from becoming a missile it is essential that it is secured within the vehicle.
- The no smoking policy should be strictly adhered to
- A warning sign indicating that the vehicle is carrying oxygen should be displayed in the window.
- Keep a window open for ventilation so that oxygen does not accumulate in the car.
- Avoid using a fuel station while the oxygen is in use.

Vehicle Test Standards

Vehicle Testing

- 5.26 No vehicle shall be first licensed or re-licensed unless the vehicle has passed the vehicle inspection at District Council's testing station. All Hackney Carriage & Private Hire vehicles after 5 years (date as shown on DVLA V5 registration document) shall have a vehicle compliance test at Testing Station every 6 months. In addition, an authorised officer of the District Council may inspect all vehicles for first licensing and upon renewal.
- 5.27 The District Council will not grant/renew a vehicle licence unless the person examining it (on behalf of the District Council) has confirmed that it meets the standards specified in The District Council's Hackney Carriage & Private Hire Vehicle Compliance Testing Standards Code of Practice (See Annex 5) and, at the same time, the vehicle has been certified roadworthy to MOT standard and has a current MOT certificate. Vehicles of a class that are not subject to 'EU Type approval' and are being tested for the first time will be additionally tested to ensure tyres and any other aspect of the vehicle are safe and mechanically sound for the benefit of passenger.
- 5.28 Costs of such testing is payable by the person wishing to licence the vehicle. In addition the history of the vehicle may be taken into consideration when determining whether the vehicle should be licensed.
- 5.29 The 6 monthly compliance test certificate required for vehicles over 5 years old must be produced to the District Council within 7 days of the date of the test. Tests can be carried out up to one calendar month before the 6 monthly point of the licence.

- 5.30 A vehicle which fails an inspection/safety check during the currency of a licence with The District Council will have the fault(s) rectified and the vehicle re-inspected within 2 months of the original inspection – failure to do so will lead to the automatic revocation of the vehicle licence.
- 5.31 A vehicle may be inspected by an authorised officer of the District Council or a Police Officer, at any reasonable time. If the person inspecting the vehicle is not satisfied as to the fitness of the vehicle he may give written notice to the proprietor/operator to make the vehicle available for further inspection and testing at such reasonable time and place as may be specified and the vehicle licence may be suspended until the authorised officer or police officer is so satisfied. If the authorised officer or police officer is not satisfied within two months of the initial inspection the Vehicle licence shall be deemed revoked. An authorised officer or police officer may permit other persons to examine the vehicle on their behalf (e.g.DVSA).

Altered Vehicles

- 5.32 Any vehicle which has been altered from the original manufacturers specification, re-registered or has been an insurance loss (categories C and D only) shall only be considered for licensing if the vehicle has been subjected to a satisfactory IVA or VIVA test (engineers report) from the Driver and Vehicle Standards Agency (DVSA) Vehicles without a DVSA engineers report will only be considered for licensing if they have been built to the manufacturers original specification. The IVA test is appropriate for vehicles not previously registered in the UK, and a VIVA for vehicles registered in the UK that needs to prove compliance.

Category A and B write offs will not be considered fit for licensing.

Vehicle Inspections

- 5.33 All vehicles being presented for testing at the District Council testing station shall be in clean condition to allow the tester to inspect the vehicle. The tester may refuse to test a vehicle that does not conform to this requirement.

Exterior Bodywork and Wheel trims

- 5.34 The bodywork of the vehicle shall be in good condition and shall be as originally fitted by the manufacturer. Wheel trims must be fitted to all road wheels where part of the manufacturer's original specification.

Vehicle Accidents / Damage to Vehicle

- 5.35 The proprietor of a private hire/hackney carriage vehicle must report to the District Council (by way of a prescribed accident notification and vehicle damage form) as soon as possible or in any event within 72 hours, any accident or incident which has caused damage to the vehicle or to any other property (i.e. other vehicle, fence post etc.). Forms for completion can be obtained from the Council website at www.fenland.gov.uk

First Aid and Fire Equipment

- 5.36 The following equipment shall be provided and maintained in all licensed vehicles at all times.

Fire Extinguisher

- 5.37 Conditions for all licensing vehicles require that a 1kg dry powder or a 2 litre AFFF fire extinguisher should be carried in the vehicle at all times. These extinguishers should be replaced when they are no longer serviceable (i.e. rusty or broken). All fire extinguishers must be maintained in accordance with BS5306 Part 3 i.e. they must have an annual service, a five-yearly service and refilled. These tests must be carried out by a BAFE certified engineer and new tags and seals must be placed on each extinguisher after inspection.
- 5.38 Unique identification tags will be provided for each extinguisher and must be affixed to the extinguisher at all times.

First Aid

- 5.39 The first-aid kit is for self-administration only and which complies with the requirements laid down by the Department of Transport for taxis and minibuses. The following contents must be presented in a secured suitable container marked 'First Aid' positioned so that it is readily available for use:

- 10 x medifresh antiseptic wipes or equivalent
- 1 x 7.5cm bandage
- 2 x triangular bandages
- 24 x assorted plasters
- 3 x large ambulance dressings
- 2 x eye pads and elastic to secure
- 12 x assorted safety pins
- 1 x pair scissors
- 2 x pairs disposable gloves

Radio Scanning Devices

- 5.40 No radio scanning devices of whatsoever type or sort may be fitted to, carried in or used in or in the vicinity of any Hackney Carriage or Private Hire Vehicle during the currency of the licence.

CCTV Cameras

- 5.41 Licensed Vehicle proprietor may, subject to the written approval of the District Council, install and use a visible closed circuit TV surveillance camera in their vehicle which face outward and are for insurance purposes only. The camera must not record audio sound within the vehicle.
- 5.42 There is no requirement to display signage where outward only facing cameras are fitted.

Change of Address

- 5.43 A licence holder on changing address shall notify the District Council, in writing, of such change within 7 days.

Citizen Band Radios

- 5.44 No citizen band radios may be fitted in any Hackney Carriage or Private Hire Vehicle whilst it is licensed.

Upholstery

- 5.45 All upholstery shall be clean and in a well maintained condition. No tear, crack, hole or burn will be acceptable other than 'fair, wear & tear'. Upholstery includes seats, headrests, armrests, carpets and other trim.

Ventilation

- 5.46 All vehicles shall have suitable and adequate ventilation.

Fittings

- 5.47 All fittings shall be properly maintained and in good working order. Fittings include clocks, interior lights, sun blinds, door surrounds, grab handles, other equipment provided for passenger comfort and any equipment in, on or forming part of the vehicle including wheelchair ramps and securing fitments where the vehicle is to be licensed to carry wheelchair bound passengers.

Roof and Floor Coverings

- 5.48 These should be clean and in good condition, with no tears or other damage.

LPG Conversions for existing licensed vehicles

- 5.49 Any vehicle proprietor converting their licensed vehicle to run on Liquid Petroleum Gas (LPG) must notify the Council of such change and comply with the following conditions.
- a. The installation of a LPG tank must be undertaken by an LPG approved installer.
 - b. That the proprietor produces a certificate of compliance by an approved LPGA installer.
 - c. That the LPG tank fitted must be a multi-valve tank and be fitted with a sealed tank box made from aluminium and vented to the atmosphere.
 - d. That the vehicle displays on the front and rear screens, a sticker stating that the vehicle has been fitted with a LPG tank for the purpose of alerting the emergency services in the event of an accident.
 - e. A doughnut tank is fitted in the spare wheel well of the boot, the spare wheel must be securely placed in a position not obstructing the entire luggage space.

- f. The proprietor of the vehicle must notify DVLA Swansea of the change in fuel from petrol to both LPG and petrol.
- g. The vehicle must be annually serviced by a person competent in LPG powered vehicles.

New Applicants – Vehicles Powered by Liquid Petroleum Gas (LPG)

- 5.50 An applicant for a licence involving a vehicle which has been converted to run on LPG will be required to produce, prior to a licence being issued, a certificate stating that the LPG system has been fitted in accordance with LPGA Code of Practice II.
- 5.51 The vehicle will be required to undergo an annual service by a person competent in LPG powered vehicles in addition to the Councils Inspection standards.
- 5.52 If an LPG conversion involves installation of an LPG fuel tank in a vehicle's boot space (and possible relocation of the spare wheel) it shall be a requirement that an amount of space shall remain free for the storage of a reasonable amount of luggage and any spare wheel displaced as a result must be stored in a location that does not impinge on the passenger carrying area of a vehicle.

Tinted Windows

- 5.53 No glass, with the exception of a tinted sun-strip along the top of the windscreen, shall be tinted to such an extent as to obscure the view of the inside the vehicle under normal workshop lighting conditions from a distance of 4 metres. Stretched Limousines are exempt from this requirement.

Unfit Vehicles

- 5.54 Unfit Vehicle notices can be issued by Authorised Officers, Vehicle Inspectorate, DVSA and Police Officers where vehicle defects give cause for concern.
- 5.55 Immediate Unfit Notices will be given if the vehicle appears to be unsafe to carry members of the public. Once a Notice is issued the vehicle must not be used for hire with immediate effect. The vehicle must be presented to either an officer or the Councils test centre with the faults rectified. Only after this will the Notice be lifted and the vehicle can then be used for hire.
- 5.56 If the Notice is not lifted within 2 months, the vehicle licence is deemed as being revoked.
- 5.57 Deferred Notices can be issued which means the vehicle can continue to be used for the time specified and the faults rectified within a specified time. When the faults are rectified the vehicle must be present to the Council testing centre.

Advertising on the Outside of a Vehicle

- 5.58 During the currency of the licence advertising will be permitted on licensed vehicles, subject to the following;
 - a. The proprietor of a licensed vehicle shall not display or permit to be displayed on the vehicle any sign or advertisement whatsoever unless written permission has been obtained from the Licensing Authority.

- b. Advertising is to be limited to the back door panels of licensed vehicles only Advertising on parts of the vehicle in addition to the back door panels may be considered but only after prior written approval of the Council has been given. However, no advertising on the windows of the vehicle will be permitted.
- c. All advertisements shall comply with the British Code of Advertising Practice and shall be in a form acceptable to the Advertising Standards Authority. The Council reserves the right to withdraw from display any advertisement which may be considered inaccurate, misleading, unlawful, defamatory, in bad taste or of an unacceptable standard.
- d. No advertisement shall relate to or advertise alcohol, nudity, gambling, smoking materials or be of a political nature.
- e. The same advertising must be displayed on the nearside and offside doors of the vehicle.
- f. Advertising may not be stuck over door trims. Door trims may not be removed to accommodate advertising.
- g. In the case of Private Hire Vehicles advertising is subject to the specific exclusion of the words 'taxi', 'cab' or 'hire' the use of which will not be permitted.

5.59 The Council reserves the right to withdraw from display any advertisement which may be considered inaccurate, misleading, unlawful, defamatory, in bad taste or of an unacceptable standard.

Vehicle Identification

Licence Plates

- 5.60 The vehicle licence plate shall be securely fixed and displayed outside and on the rear of the vehicle and shall be clearly visible during daylight hours from a distance of not less than 5 metres. The licence plate must not obstruct any signage prescribed by the Council or any lights or the vehicles registration mark. Any items such as tow bars must not obstruct and licence plate.
- 5.61 The licence plate shall be displayed in a vertical position and firmly fixed to the outside of the vehicle at the rear. Velcro or cable tie fastenings shall not be permitted. The plate must be prominently displayed as to be readily visible to members of the public and that the figures and numbers endorsed thereon are distinct and legible.
- 5.62 The licence plate is the property of the Council to whom it must be returned within 7 days of demand if the licence is suspended, revoked or not renewed for any reason.
- 5.63 The internal vehicle licence shall be fixed and displayed inside the front windscreen on the passenger side of the vehicle in the bottom corner and must not be obstructed.

Reporting a Lost, Damaged or Stolen Licence Plate

- 5.64 The vehicle proprietor/licensee shall inform the Council within 72 hours should the licence plate become lost, damaged or stolen. If lost or stolen the matter shall be reported to the police and a relevant reference number shall be required. (i.e. Crime Number or Lost Property reference)

List of drivers to be maintained

- 5.65 The vehicle proprietor/licensee shall maintain a list of names and addresses of all persons that have use of that licensed vehicle. The list shall be made available to authorised officers upon request.

Trailers attached to Licensed Vehicles

- 5.66 The proprietor of a licensed vehicle may attach a trailer for carrying luggage when required, subject to the completion of the relevant application, and providing that an external trailer licence plate is affixed to the rear of the trailer. The licence plate must be the same as the vehicle licence plate, with the addition of a trailer symbol.

5.66.1 Trailers cannot be used by Hackney Carriage vehicles when plying for hire on a Hackney Carriage.

5.66.2 The trailer must at all times comply with all Road Traffic legislation requirements, in particular those laid down in the Road Vehicles (Construction and Use) Regulations 1986.

5.66.3 Trailers must comply with the following standards:

- a) Unbraked trailers shall be less than 750kg gross weight
- b) Trailers over 750kg gross weight shall be braked acting on at least 2 road wheels
- c) The towing vehicle must have a kerb weight at least twice the gross weight of the trailer
- d) A suitable lid or other approved means of enclosure shall be fitted to secure the contents within the trailer whenever in use.
- e) The maximum permissible length of the trailer shall be 7 metres including the drawbar and coupling.
- f) The width of the trailer shall not be greater than the towing vehicle subject to no trailer being wider than 2.3 metres.
- g) The Maximum length for braked axle trailers is 5.54 metres.

- 5.67 Once a vehicle licence has been granted the vehicle remains a licensed vehicle until the licence expires or is revoked. Only drivers licensed by Fenland District Council may drive the vehicle.

- 5.68 There is no age limit in place for a vehicle to be licensed.

5.69 A vehicle that is already licensed with a different authority CANNOT be licensed by Fenland District Council, as the vehicle would be unable to meet the conditions of the vehicle licence.

6.0 Hackney Carriage Vehicles

6.1 The following are conditions attached to the hackney carriage vehicle licence. These conditions are additional to the requirements imposed upon proprietors by the Town Police Clauses Act 1847 and the Local Government (Miscellaneous Provisions) Act 1976. Breach of any of these conditions may lead to suspension or revocation of the licence and/or prosecution. These conditions are equally applicable when the hackney carriage is being used for private hire purposes.

Wheelchair Accessible Vehicle Specifications

Restriction on Numbers of Licensed Vehicles

6.2 The Council does not restrict the number of hackney carriage licences that it issues. Licence numbers. Hackney licenses issued, from 320 onwards must be wheelchair accessible vehicles.

First Registration

6.3 Any additional Hackney Carriage Vehicle licenses issued must be wheelchair accessible (plate 286 onwards)

Wheelchair Occupant Space

6.4 A wheelchair space shall not be less than:

- 1200mm measured in the longitudinal plane of the vehicle
- 750mm measured in the transverse plane of the vehicle
- 1300mm measured vertically from any part of the floor of the wheelchair space.

A wheelchair space shall allow the carriage of a wheelchair and a wheelchair user.

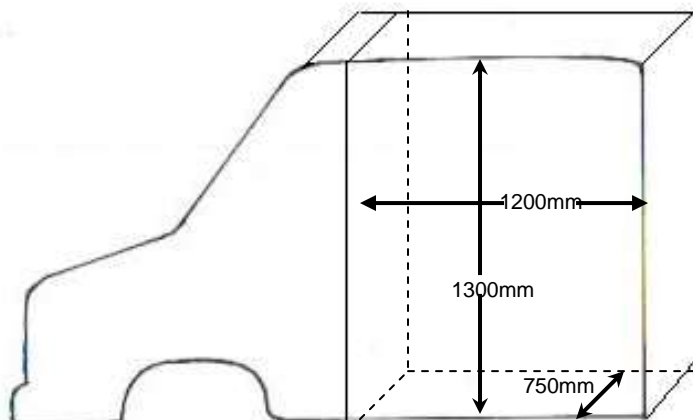

Lifts/Ramps

- 6.5 Access to the vehicle must be possible from the road or pavement either by a lift or ramp. Any power-operated device must be capable of manual operation in the event of a power failure. The boarding device must have a safe working load of 300kg and operate under normal loading conditions without undue deflection.

Ramps

- 6.6 A ramp should be of slip resistance material and at least 750mm in width. The ramp should be capable of being deployed both onto the road and onto a 125mm high kerb. The ramp when deployed should be securely located at the point of entry to the vehicle. For side loading the ramp when deployed to the pavement should not exceed a slope of 1:4. For rear loading the ramp when deployed to the road should not exceed 1:4. When not in use the ramp should be securely stored in such a manner as not to block any of the vehicle doors and not to present a hazard to the vehicle occupants.

Lifts

- 6.7 The lift platform must be not less than 750mm in width and not less than 1200mm in length. The ramp should be equipped with a device to prevent the wheelchair rolling off and should operate at a vertical speed of less than 0.15m/s.

Wheelchair securing mechanism anchorage

- 6.8 A 4 point anchorage system must be fitted, comprising two for attachment at the front of the wheelchair and two at the rear of the wheelchair, in accordance with ISO 10542-2.

Wheelchair securing mechanism

- 6.9 A suitable securing mechanism must be provided to secure the wheelchair in position and the wheelchair should be locked in place before the journey commences. The occupant of the wheelchair must be provided with an occupant restraining system (seatbelt).

Insurance

- 6.10 The proprietor shall keep in force, in relation to the use of the hackney carriage, a policy of insurance in respect of public hire and complying with the provisions of Section 145 of Part VIA Road Traffic Act 1988 which covers third party liability both in respect of physical injury or death and in respect of damage to personal belongings. The certificate of insurance and schedule must be produced, on demand to an authorised officer of the District Council for inspection.
- 6.11 It shall be the responsibility of the proprietor of a hackney carriage to produce proof of continuous insurance cover in respect of public hire. The insurance proof is to be reviewed by the licensing authority within seven days of the expiry of the preceding certificate or cover note.

- 6.12 If the proprietor fails to produce a certificate of insurance cover on request he shall produce it forthwith or within seven clear days of the request to an authorised officer of the District Council. Failure to comply may result in suspension of the Hackney Carriage Vehicle licence.

Transfer of interest in the vehicle

- 6.13 Where there is a transfer of interest in whole or in part, in a vehicle to any other person not specified in the vehicle licence the licence holder Notify the District Council within 14 days using the appropriate The form must be accompanied by the fee and supporting documents.

Taximeter

- 6.14 All Hackney Carriage vehicles licensed or to be licensed shall have a fully automatic calendar controlled taximeter fitted. Each taximeter shall be tested by one of the Council's approved installers/testing centres in order to establish that the meter does not produce a fare in excess of the maximums prescribed in the current Hackney Carriage Fare Tariff approved by the District Council.
- 6.15 The driver of a Hackney Carriage Vehicle must use the taximeter for all journeys within the Fenland District boundaries. For journeys commencing within and ending outside the District boundaries, the driver can negotiate the fare with the hirer prior to commencement of the journey.
- 6.16 The taximeter shall be placed in a safe position and so far as possible so that all letters and figures on the face thereof shall be at all times plainly visible to any persons being conveyed in the carriage. For that purpose, the letter and figures shall be capable of being suitably illuminated during the period of hiring.
- 6.17 The driver of a hackney carriage shall:
- a) at the commencement of the journey activate the taximeter so that the word 'hired' is clearly visible and shall keep the taximeter operating until the termination of the hiring. – 'Commencement of the journey' means:
 - When the hirer enters the vehicle.
 - When the driver has attended at an appointed place, and has made his presence known to the hirer.
 - When the driver has presented him/herself at an appointed place at a specified time.
 - b) not cause the fare recorded on the taximeter to be cancelled or concealed until the hirer has had a reasonable opportunity of examining it and has paid the fare.
- 6.18 The driver of a Hackney Carriage Vehicle shall when standing or plying for hire keep the taximeter locked in the position in which no fare is recorded on the face

of the taximeter and operate a sign, which shall bare the words 'For Hire' in clear legible letters.

- 6.19 Any taximeter fitted to a Hackney Carriage Vehicle, which has been adjusted or repaired shall have the taximeter retested by the District Council's approved testing stations.
- 6.20 The taximeter shall clearly display a fare not exceeding the rate or fare approved by the District Council.

Interference with Equipment

- 6.21 The driver of a Hackney Carriage shall not tamper with or permit any person to tamper with, any taximeter with which the vehicle is provided, with the fittings thereof, or with the seals affixed thereto, nor with any other equipment attached to or forming part of the vehicle.
- 6.22 The taximeter and all the fitting thereof shall be so affixed to the carriage with security seals or other appliances that it shall not be practicable for any person to tamper with them except by breaking, damaging or permanently disabling the security seals.

Inspection of Vehicle and Taxi Meter

- 6.23 A taxi meter fitted to a licensed vehicle may be inspected by an authorised officer of the District Council or by a Police Officer at all reasonable times.
- 6.24 If the officer or constable inspecting the vehicle is not satisfied as to the fitness of the vehicle or the accuracy of the meter, he may without prejudice to the taxi meter condition, give written notice to the proprietor to make the Hackney Carriage and/or taxi meter available for further inspection and testing at such reasonable time and place as may be specified, and the vehicle licence may be suspended until the officer or constable is satisfied as to the vehicles fitness or as to the accuracy of the taxi meter.
- 6.25 If the officer or constable is not so satisfied within two months of the initial inspection, the Hackney Carriage Licence shall be deemed revoked.

Roof Signs

- 6.26 All Hackney Carriage vehicles must be fitted with roof-mounted signs.
- 6.27 Roof signs fitted upon a Hackney Carriage Vehicle must be white in colour and shall be securely fitted to the vehicle. Roof signs ~~and~~ must be of a design and shape approved by the District Council.
- 6.28 All Hackney Carriage Vehicle roof signs shall display the wording 'taxi' on the front and the words 'Fenland District Council' together with the carriage licence number on the back (except in the case of a London Style cab). The sign shall be capable of being illuminated internally in such a manner that the word 'TAXI', Fenland District Council and the carriage licence number, is illuminated at all times when the vehicle is plying for hire, but not otherwise.

- 6.29 All wording shall be black in colour and the word 'TAXI' must not be less than 125mm in height. Wording on the rear of the roof light must not be less than 25mm in height.

Proprietors Responsibility

- 6.30 During the period of the licence the holder shall be in direct control of the day to day running of the vehicle including the responsibility to ensure the meter is operating correctly and fulfils the requirement of conditions, byelaws and current fare charge card as approved by Fenland District Council.

Vehicle Inspections

- 6.31 A vehicle which fails a compliance inspection/safety check during the currency of a licence will have the fault (s) rectified and the vehicle re-inspected within 2 months of the original inspection – failure to do so will lead to the automatic revocation of the vehicle licence.
- 6.32 A Hackney Carriage may be inspected by an authorised officer of the District Council or a police officer, at all reasonable times. If the person inspecting the vehicle is not satisfied as to the fitness of the vehicle he may give written notice to the proprietor to make the vehicle available for further inspection and testing at such reasonable time and place as may be specified, and the vehicle licence may be suspended until the officer or police officer is so satisfied.
- 6.33 If the authorised officer or police officer is not so satisfied within two months of the initial inspection the Hackney Carriage vehicle licence shall be deemed revoked.

Alteration of Vehicle

- 6.34 During the currency of the Licence, no material alteration or change in the specification, design, condition or appearance of the vehicle shall be made without the prior written approval of the District Council. All vehicles must have four doors with the exception of purpose built vehicles.

Passengers

- 6.35 The proprietor or owner of a Licensed Hackney Carriage shall not permit to be conveyed in the vehicle a greater number of persons than prescribed on the licence for the vehicle.
- 6.36 The driver of a Licensed Hackney Carriage shall not, without the consent of the hirer of the vehicle, convey or permit to be conveyed any other person in the vehicle.
- 6.37 A driver shall not refuse to carry fewer persons than the number marked on the plate.

Unattended Taxis

6.38 No Hackney Carriage may be left on a taxi rank designated by Section 65 Local Government (Miscellaneous Provisions) Act 1976 or a Local Traffic Order without a licensed driver in attendance to take care of it whilst plying for hire.

7.0 Private Hire Vehicles

Roof Signs

7.1 The Council will not permit a Private Hire Vehicle to be fitted with a roof mounted sign of any kind.

Vehicle Signage

7.2 The Private Hire vehicle shall not display any sign, which consists of or includes the word 'Taxi' or 'Cab' whether singular or plural, or 'Hire' or any word of a similar meaning or appearance to any of those words, whether alone or as part of another word. The only exceptions are:

- The word 'hire' displayed on a Private Hire vehicle is when the word is used in conjunction with the word Private to form the word 'Private Hire'.
- To meet the requirements of the Condition below

7.3 A sign must be displayed in a prominent position on each front side door of the vehicle displaying the Fenland District Council logo and specifying the operator name, with a telephone number for bookings, with the wording 'Pre-Booked Only, Insurance invalid unless booked with operator'. The sign must be in the prescribed format of black writing no smaller than 60mm in height on a yellow background with a black border and must be affixed to the vehicle by an authorised sign maker. Removable signs e.g. magnetic will not be permitted. The signage is only available from the District Council's Licensing team and must be fitted within 14 days of the signage being ready and available with the signage company.



Change of Use

7.4 Once a Hackney Carriage or Private Hire vehicle has passed first registration it will not be considered a new application if a change of use between either

category is requested, or if the licence has previously lapsed and is being reinstated. This is conditional that the vehicle held a vehicle licence issued by this authority in the preceding 3 months, and that the previous licence holder makes the new application.

Transfer of interest in the vehicle

7.5 Where there is a transfer of interest in whole or in part, in a vehicle to any other person not specified in the vehicle licence the licence holder must notify the District Council within 14 days using the appropriate form. The form must be accompanied by the fee and supporting documents.

8.0 Special Event Vehicles

Application in Writing

8.1 Any person wishing to apply for a special event vehicle licence will be required to apply in writing to the Licensing Authority stating the type and age of the vehicle they intend to use and the reasons why the vehicle should be considered for this vehicle category.

8.2 Vehicles issued with a special event licence must only be used for special occasions and executive business contracts.

8.3 Vehicles licensed within this category shall not be used for everyday private hire use, e.g. 'school contracts' but must work under the control of a private hire operator..

Sale or Supply of Alcohol

8.4 The licensee shall not facilitate the sale of alcohol unless there is in force an appropriate authorisation under the Licensing Act 2003 (either a premises licence or temporary event notice) permitting the sale of alcohol..

Types of Vehicle

8.5 Special event vehicles must be licensed as private hire vehicle and fall into one of the three categories specified below:

- a. Executive vehicles
- b. Stretched limousines
- c. Historic vehicles.

Age Requirements

8.6 Executive vehicles presented for licensing for the first time should not normally be older than three (3) years on the day the application is received.

- 8.7 Stretched limousines presented for licensing for the first time should not be older than seven (7) years on the day the application is received.
- 8.8 Historic vehicles presented for licensing for the first time must not have been constructed after 1 January 1973, in accordance with DVLA taxation class for Historic Vehicles.

Licence Plate

- 8.9 The vehicle licence plate must be fixed to the inside of the boot lid on the vehicle.

Communication Equipment

- 8.10 No vehicle shall be fitted with a two-way radio system.

Dress Code

- 8.11 Drivers of special event vehicles will be required to observe a 'smart casual' dress code e.g. NO jeans, NO t-shirts, NO sportswear etc. A minimum acceptable standard for men includes shoes, trousers and a formal shirt (i.e. with collar). For women a minimum acceptable standard includes shoes, trousers or skirt and a blouse or jumper.

Minimum Booking Fee

- 8.12 Vehicles must not be offered for hire for less than a stipulated minimum-booking fee. A receipt must be given to the customer in all cases, unless covered by a contract and receipts and contracts should be available to authorised officers of Council for inspection.

Stretched Limousines

- 8.13 A "stretched limousine", is a saloon type vehicle that has undergone an increase in length by extending the wheelbase after manufacture. An "American stretched limousine" is a stretched limousine imported from the USA and typically will have been manufactured originally by Lincoln (Ford) or Cadillac.
- 8.15 The purpose of this policy and subsequent conditions is to protect public safety. The conditions will apply in addition to the Authorities standard conditions for private hire vehicles and take account of the fact that stretched limousines will:
- a. travel generally at slower speeds than normal licensed vehicle;
 - b. not normally overtake other vehicles;
 - c. be easily recognisable by the hirer;
 - d. be heavier and considerably longer than standard cars;
 - e. be adapted or converted by someone other than the original manufacturer.

- 8.16 For the purposes of calculating the seating capacity of a vehicle the minimum width of a passenger seat must be 400mm (16 inches). In the case of an 'L' shaped seat, sufficient space must be made available in the corner to prevent the passenger on one side of the corner encroaching on the passenger on the other side.
- 8.17 In the case of a stretched limousine, or American stretched limousine, where the vehicle has been constructed or adapted to seat up to 8 passengers, originals of the following documentation must be provided to the Licensing Authority before an initial application for a vehicle licence can be considered:
- a. completed importation documentation where applicable and single vehicle approval (SVA) certificate. A Minister's Approval Certificate will **NOT** be acceptable;
 - b. proof the 'stretch' was performed by the manufacturer or by a coachbuilder approved by the vehicle manufacturer i.e. American limousines must have been built by an approved coachbuilder under the QVM programme for Ford Vehicles or the CMC programme for Cadillac Vehicles;
 - c. DVLA Registration Document (V5);
 - d. valid certificate of insurance with cover for hire and reward;
 - e. current MOT certificate issued by an approved testing station;
 - f. where applicable, an installation certificate from a Liquefied Petroleum Gas Association (LPGA) approved UK vehicle conversion company, in the case of vehicles converted to run on LPG;
 - g. valid Road Vehicle Excise licence disc.

Replacement Parts

- 8.18 Any replacement parts fitted to stretch limousine vehicles must meet the approved standards of the stretched specifications, i.e. tyres will not only have to meet the size specifications, but must also meet the weight specification.

Window Tints

- 8.19 Stretch limousines are exempt from conditions in this policy regarding tinted windows

Fire Extinguisher & First Aid Kit

- 8.20 The vehicle must contain a fully functional portable multipurpose powder type fire extinguisher, which bears a kite mark and is tested and installed in accordance with HSE requirements. The vehicle must also carry a HSE approved First Aid Kit.

Alcohol

- 8.21 If passengers are under the age of 18, there should be no alcohol in the vehicle for consumption or otherwise.

Entertainment

- 8.22 The licence holder shall not supply any media that, given its age classification or content, is unsuitable for the age of the passengers in the vehicle.
- 8.23 The licence holder shall ensure that a performing rights licence is held where appropriate.

Seat Belts

- 8.24 Seatbelts must be fitted to all seats and must be worn at all times by passengers whilst the vehicle is in motion.

Advertisements

- 8.25 No other signs, notices or any other markings will be displayed on or in the vehicle without the written permission of the council.

Fog Machines, Lasers, Fibre Optics, Disco Balls, Jacuzzis

- 8.26 Use should comply with relevant health and safety regulations and should not be used in a manner, which is likely to distract the limousine driver or other road users.

Strobe Lights

- 8.27 Where strobe lights are to be used, those hiring the vehicle should be verbally notified in advance and the person making the booking notified both verbally and in writing. Strobe lighting should not be used/be turned off if so requested. Use should comply with relevant health and safety regulations and should be used in a manner which is likely to distract the limousine driver or other road users.

Glass Mirrored Ceilings

- 8.28 Need to be made of appropriate alternative to glass.

Private Hire Operator – Additional Requirement

- 8.29 Special event vehicles must be specifically requested by the customer and it is not for the operator to determine which class of vehicle should be assigned to the booking. In addition to the Private Hire Operator records required under 10.23 of this policy, operators of special event vehicles are to maintain a record of the

nature of the special event i.e. why the customer requested a special event vehicle.

9.0 Hackney Carriage & Private Hire Driver's Licences – Including Dual Licences

9.1 Before a person is licensed, or renews a licence, as a licensed driver the following requirements shall be met:

9.1.1 All applicants/Drivers must be in possession of a full driving licence issued by the DVLA or a licence from an EEA or EU state and that licence must have been in place, for at least, the preceding 12 months.

9.1.2 Any applicant must be medically examined by a qualified medical practitioner at the practice where the applicant is registered and must be considered fit enough to meet at least the standards required for the grant of a Group II driving licence as recommended by the Driver Vehicle Licensing Agency. Medical certificates supplied upon first registration will be accepted if dated up to 6 months before the date of initial application.

9.1.3 An enquiry shall be made of the DVLA to establish the validity of any applicant's UK driving licence and any motoring convictions recorded against him/her in order to confirm that the applicant is a fit and proper person to hold, or continue to hold, a licence. The applicant will be required to authorise the District Council to make such enquiries.

9.1.4 An applicant's criminal record shall be obtained via the Disclosure and Barring Service at "enhanced" level in order to confirm that the applicant is a fit and proper person to hold a licence. The applicant will be required to complete the necessary forms for the purpose. If a Disclosure and Barring Service check is not available, the applicant must provide a certificate of good citizenship or equivalent from every country where the applicant has been resident.

9.1.5 Any applicant must make a declaration (by means of a form or questionnaire provided for the purpose) as to any criminal or motoring convictions recorded or pending against him/her in order to confirm that the applicant is a fit and proper person to hold a licence.

9.2 The DVLA driving licence must cover the appropriate category for the vehicle being driven.

9.3 All holders of a licence including a Dual Driver's licence shall be required to take and pass a medical examination at age 45, then every five years after the age of 45 and then annually from the age of 65 years. A driver under the age of 65 with a controlled medical condition may also be required to undergo a full medical annually or at any other time that may be prescribed by a medical practitioner. An authorised officer of the District Council may, upon reasonable request ask for a driver to complete a medical at any time.

9.4 If a medical certificate is not produced when requested, the District Council may consider suspension/revocation of a Drivers licence. If there is a change in a

Drivers medical fitness to drive a vehicle, they must notify the Licensing Team as soon as possible or no longer than 72 hours after the change in circumstances.

- 9.5 In relation to the consideration of convictions and cautions recorded against persons the District Council has adopted the policy set out in Annex section of this policy (Guidelines relating to the relevance of convictions).
- 9.6 A Driver's Licence including a dual Licence, shall be valid for a maximum term of three years (unless a shorter period is appropriate).
- 9.7 If a Driver accrues 7 or more points in a 3 year period on his/her DVLA driving licence, they will be required to appear before a Licensing Panel in order for their continued suitability to hold a driver's licence to be assessed.

Drivers of Private Hire vehicles

- 9.9 The driver of a private hire vehicle while driving or in charge of such a vehicle shall not:
 - 9.9.1 tout or solicit or cause or procure any other person to tout or solicit on a road or other public place any person to hire or to be carried for hire in any vehicle;
 - 9.9.2 ply for hire by offering a vehicle for immediate hire while they or that vehicle are on a road or other public place;
 - 9.9.3 accept an offer for the immediate hire of a vehicle while they or that vehicle are on a road or other public place except where the offer is first communicated to the driver in person by telephone or vehicle radio without him / her in any way procuring the offer.
 - 9.9.4 In this condition "road" means any highway and any other road to which the public has access and includes bridges over which a road passes.
- 9.10 When hired to drive to a particular destination, a driver shall (subject to any directions given by the hirer) proceed to that destination by the shortest available route.
- 9.11 Must at all times carry a written record of all bookings, detailing the particulars of each journey to be undertaken and the name and address of the person who has made the booking.
- 9.12 Must only accept bookings that have been passed via the premises of the licensed operator for whom the driver works and immediately upon receipt of such a hiring the driver must record the same in his/her own record of bookings before proceeding to the pick-up point.
- 9.13 The record of bookings must be produced on demand to an Authorised Officer of the District Council or a Police Officer.
- 9.14 The driver of a Private Hire vehicle, when not engaged in a pre-arranged booking, must not park in such a position or location on the public highway so as to give the appearance of being for hire.

9.15 The driver **MUST**, whilst driving a Private Hire vehicle:

- a. confirm the passenger's name and destination;
- b. confirm the fare before the commencement of the journey in accordance with the District Council's regulations.

Conduct of Driver

9.16 The driver shall at all times:

- 9.16.1 be clean and respectable in his/her dress and person and behave in a civil and orderly manner.
- 9.16.2 take all reasonable steps to ensure the safety of passengers conveyed in, entering or alighting from the vehicle driven by him/her.
- 9.16.3 not without the express consent of the hirer play any radio or sound reproducing instrument or equipment in the vehicle other than for the purpose of sending or receiving messages in connection with the operation of the vehicle.
- 9.16.4 not cause or permit the noise emitted by any radio or other previously mentioned equipment in the vehicle which he/she is driving to be a source of nuisance or annoyance to any person, whether inside or outside the vehicle.
- 9.16.5 Not sound a horn whilst stationary except in traffic and not at all between 23:00 and 07:00 hours in areas where there is a 30 mph speed limit in force or sounding the vehicle horn to announce arrival or tout for business.
- 9.16.6 Not smoke cigarettes or tobacco or any other substance in the vehicle at any time, even when the vehicle has no passengers.
- 9.16.7 Ensure that the interior and exterior of the vehicle is presented for service in a clean, well maintained and serviceable condition.
- 9.16.8 Not without the express consent of the hirer, drink or eat in the vehicle.
- 9.16.9 Ensure that licensed vehicles parked on a public highway or in the vicinity of the operator's premises are parked in a legal manner and are not left unattended on yellow lines or other restrictive road markings when those restrictions are in force and do not cause an obstruction or cause a nuisance in the vicinity of any operating base.

Change of Address

9.17 The driver shall notify The District Council in writing of any change of his/her name, address and/or telephone number during the period of the licence within seven days of the change taking place.

Change of Operator

- 9.18 The driver shall notify the District Council in writing of any change in the private hire operator he/she is working under the control of within 7 days of the change taking place.
- 9.19 The existing licence must be returned to the Council together with the appropriate fee, for the drivers licence to be duly amended and re-issued.

Convictions, Cautions, Driving Offences & Charges

9.20 The driver shall notify the District Council in writing if he/she receives any summons, charge, conviction, caution, formal or informal notice, County Court Judgement or fixed penalty notice within seven days of receiving such. The written notification should include the following details:

- Offence / alleged offence;
- Date, place & time of offence/alleged offence;
- Whether acting as a hackney/private hire;
- If motoring offence:
 - whether paying passengers carried;
 - speed or alleged speed;
 - speed limit for road;
 - Punishment e.g. amount of fine, number of penalty points issued etc.
 - whether speed awareness course undertaken

9.21 Depending on the circumstances or the number of penalty points accrued on their DVLA driver's licence, drivers may be referred to a Licensing Panel. In doing so, the Panel must have regard to all convictions, police cautions, charges, driving convictions, complaints of unacceptable conduct/behaviour, breach of licence conditions and other convictions obtained during the course of a Licence.

9.22 Drivers should be aware that if they fail to comply with this requirement it may prevent the District Council from renewing their driver's licence under delegated authority.

9.23 In the event of a disqualification from driving, a driver shall immediately inform the District Council and return their driver's badge.

Driver's Identification Badge

9.24 The driver must at all times when acting as the driver of a licensed vehicle wear his identity badge as provided by the Council in such a manner as to be plainly and distinctly visible on the lanyard provided.. The badge must be handed over for inspection, if requested, to any Authorised Officer or Police Officer. for the purposes of the Local Government (Miscellaneous Provisions) Act 1976.

9.25 The driver of a licensed vehicle shall, when required to do so by an Authorised Officer of the Council, return the driver's badge and licence to the Council and obtain a receipt for it. The driver shall upon the expiry (without immediate renewal), revocation or suspension of this licence forthwith return the driver's badge to the Council. Badges must be renewed before the expiry date of the existing badge. If an application for renewal is not received by the renewal date the licence will lapse. In **exceptional** circumstances officers may permit late applications

If a licensed driver holds a badge with a County Council to carry passengers on school or other contracts, and that badge is suspended or revoked by the County Council, the driver shall notify the Council, in writing, within 72 hours.

- 9.26 A driver shall not damage or deface a driver's badge nor allow any other person to do so.

Driving licence

- 9.27 A driver shall produce their DVLA driving licence for inspection by an authorised officer annually and at any point during the period of the licence (within 7 days of request).

Prompt Attendance

- 9.28 The driver of a vehicle shall, if he/she is aware that the vehicle has been hired to be in attendance at an appointed time and place or he/she has otherwise been instructed by the operator or proprietor of the vehicle to be in attendance at an appointed time and place (unless delayed or prevented by sufficient cause) punctually attend at that appointed time and place.

Passengers and Luggage

- 9.29 The driver shall not carry or permit to be carried in the licensed vehicle a greater number of persons than that prescribed in the licence for that vehicle regardless of age or size.
- 9.30 The driver shall not carry or permit to be carried any child below the age of twelve (12) years or 135cms in height in the front seat of the licensed vehicle.
- 9.31 The driver shall take all reasonable precautions to ensure the safety of persons carried in or entering or alighting from the licensed vehicle.
- 9.32 The driver shall not, without the consent of the hirer, carry any other person in the vehicle.
- 9.33 All drivers shall if required:
- a) carry a reasonable quantity of passenger's luggage, ensuring its security;
 - b) afford reasonable assistance in loading and unloading luggage and removing it to or from the entrance of any building, station, or place at which the licensed driver may take up or set down the passenger.
- 9.34 The driver, who shall knowingly convey in a vehicle the dead body of any person, shall immediately thereafter notify the fact to the Licensing Team.

Lost Property

- 9.35 The proprietor or driver of a licensed vehicle must, immediately after the termination of any hiring or as soon as practicable thereafter, carefully search the vehicle for any property which may have accidentally been left therein.

- 9.36 Any property found must, within twenty-four (24) hours, be returned to the hirer or handed in to the nearest Police station, leaving it in the custody of the officer in charge on his/her giving a receipt for it.

Animals

- 9.37 The driver shall not convey in any licensed vehicle any animal belonging to, or in the custody of, him/herself or the proprietor or the operator of the vehicle. And he shall ensure that any animal belonging to or in the custody of any passenger is adequately restrained and kept in such a position so as not to distract the driver or otherwise be a cause of danger or nuisance.
- 9.38 A driver of a licensed vehicle which has been hired by or for a disabled person with their guide, hearing or prescribed assistance dog, or a person who wishes such a disabled person to accompany him in the vehicle has a duty to convey the disabled passenger's dog and allow it to remain with the passenger in the rear of the vehicle except that an assistance dog accompanying a disabled person may sit in the front of the vehicle provided that the animal is properly trained to sit in the foot well of the vehicle with the disabled passenger.
- 9.39 A driver cannot refuse to carry an assistance dog, defined by regulations as a dog which is trained by a specified charity i.e. "Dogs for the Disabled", "Support Dogs" or "Canine Partners for Independence", to assist a disabled person with a physical impairment.
- 9.40 The driver shall only be exempt from the condition on medical grounds with a certificate from the driver's doctor, and has obtained an exemption notice from the Licensing Team. The notice of exemption shall be exhibited in a prominent position.
- 9.41 A driver must not charge for the carriage of assistance dogs.

Written Receipts

- 9.42 The driver shall if requested by the hirer or passenger of a licensed vehicle provides a written receipt for the fare paid.

Fare to be demanded

- 9.43 The driver of a Private Hire Vehicle shall not demand from any hirer of a licensed vehicle a fare in excess of any previously agreed for that hiring between the hirer and the operator.
- 9.44 The driver of a Hackney Carriage shall not demand from any hirer of a licensed vehicle any fare greater than that shown on the face of the taximeter.

Breakdowns

- 9.45 In the event of a breakdown during a hiring the driver shall ensure that alternative arrangements are made for passengers to continue their journey.

Deposit of Licence (Private Hire Only)

- 9.46 If the driver is permitted or employed to drive a Private Hire vehicle by an operator he/she shall, before commencing to drive that vehicle, provide the driver's licence to the operator for retention by them until such time as the driver ceases to be permitted or employed to drive for that operator.
- 9.47 When driving a Private Hire vehicle, the driver must ensure that the operator has a Private Hire operator's licence issued by Fenland District Council.

Renewal/New Applications

- 9.48 The driver shall, prior to the date of the licence expiry for applications, make application to the Council for a renewal. If an application for renewal is not received by the renewal date the licence will lapse. In **exceptional** circumstances officers may permit late applications
- 9.49 Where operations continue after a failure to renew, prosecutions are likely to be authorised without notice.
- 9.50 All new drivers to undertake the DVSA (Driving Vehicle Standards Agency) test before being granted a licence. Existing drivers are exempt from this requirement unless the Licensing Committee determine that a driver must undertake the test to prove they are fit and proper to hold such a licence in cases where complaints of bad driving or serious driving offences are upheld.

Driver Responsibility

- 9.51 Before the commencement of duty, the licensed driver must ensure that:
- a. the vehicle is licensed in accordance with Fenland District Council's conditions;
 - b. the vehicle is correctly insured as required by the relevant Road Traffic Regulation Act or any other enactment;
 - c. he/she inspects the vehicle to ensure that it is in a fit and proper condition to be used as a licensed vehicle.

Health of the Driver

- 9.52 The holder of a driver's licence must inform the District Council immediately about the onset or worsening of any health condition likely to cause him/her to be a source of danger to the public when driving either now or in the future. (Examples are giddiness, fainting, blackouts, epilepsy, strokes, multiple sclerosis, Parkinson's disease, heart disease, angina, coronaries, high blood pressure, arthritis, disorder of vision, mental illness, alcoholism, drug taking, and loss of a limb or use of a limb).
- 9.53 Temporary conditions, other than recurrent ones, not expected to last more than three months need not be reported. Drivers who are in doubt about whether or

not their health condition is one which should be reported should consult their doctor.

- 9.54 THIS LIST DOES NOT INCLUDE ALL DISABILITIES THAT MUST BE REPORTED. THESE EXAMPLES ARE GIVEN ONLY TO INDICATE TYPES OF DISABILITY REQUIRED TO BE REPORTED.

Inspection of Documents

- 9.55 At the request of the Licensing Officers or a Police Officer, the holder of a driver's licence must within seven (7) days produce for inspection the following original documents:
- a. UK driving licence issued by DVLA, Swansea;
 - b. driver identification badge issued by the District Council ;
 - c. vehicle licence issued by the District Council;
 - d. vehicle registration document issued by DVLA, Swansea;
 - e. certificate of the policy of motor insurance or security as required by Part IV of the Road Traffic Act 1988 or any other enabling Act;
 - f. Ministry of Transport Test certificate (where appropriate)
 - g. or any other document required by the District Council for inspection.

Concealment of Licence Plate

- 9.56 The driver of a licensed vehicle must not, wilfully or negligently, cause or suffer any licence plate to be concealed from public view while the vehicle is being used for the purpose of public or private hire.
- 9.57 The driver must ensure that the vehicle plate indicating the licence number and the number of passengers it is licensed to carry must be displayed on the outside of the vehicle in a vertical position to the right hand side of the rear number plate on the bracket and fixing provided.

Mobile Phones

- 9.58 Drivers must not use a mobile telephone hand set whilst the vehicle is in motion. Any mobile telephone used in a licensed vehicle must be capable of hands free operation.

Insurance

- 9.59 The driver shall carry evidence of insurance cover in the vehicle at all times whilst on duty, showing that the vehicle is suitably insured.

Plying for Hire

- 9.60 When plying for hire in any street the driver of the vehicle shall:-
- (a) when stationary on a Hackney Carriage stand appointed by the Council or on private property cause the vehicle to be moved forward so as to fill any place previously occupied by a carriage driven off;

(b) when standing or plying for hire shall not be calling out or otherwise importune any person to hire such carriage and shall not make use of the services of any other persons for this purpose

Shortest Route

9.61 The driver of a Hackney Carriage vehicle shall not without reasonable cause or necessity prolong in distance or in time the journey for which the Hackney Carriage Vehicle has been hired.

Complaints

9.62 The driver shall advise passengers of their right to refer any complaint to the District Council

Passenger Transport Badge Holders

9.63 If a licensed driver holds a badge with a County Council to carry passengers on school or other contracts, and that badge is suspended or revoked by the County Council, the driver shall notify the Council, in writing within 72 hours.

Smoking and Electronic Cigarettes

9.64 The driver must not smoke in a licensed vehicle at any time. The use of Electronic Cigarettes (e-cigs), Personal Vaporizers (PV) and Electronic Nicotine Delivery Systems (ENDS) is also prohibited at all times- only whilst carrying fare paying passengers.

Failure to provide Information

9.65 It is the driver's responsibility to provide the following information throughout the term of their licence:

- a) DBS check every 3 years
- b) Annual DVLA Check
- c) Medical Certificate in accordance with conditions

Penalties

9.66 The Local Government (Miscellaneous Provisions) Act 1976 provides that any person who acts in contravention of the provisions of Part II of the Act shall be guilty of an offence and liable on summary conviction to a fine. In addition to such action, whether or not resulting in criminal proceedings being taken, may lead to the suspension or revocation of an existing driver's licence or refusal to renew such a licence.

9.67 These conditions are in addition to the provision of Part II of the Local Government (Miscellaneous Provisions) Act 1976.

9.68 The requirements of this legislation which affect the operations being carried out under the terms of this licence shall be regarded as conditions of this licence.

10.0 Private Hire Operators

- 10.1 A Private Hire Operators Licence shall be valid for a maximum period of five years (unless a shorter period is appropriate).
- 10.2 An Operator Licence is required to run a Private Hire Business. This licence is for the operation of the business only. Separate licences for vehicles and drivers must also be obtained. The base for this business should be located within the Fenland District Council area. Persons who wish to operate a business from outside the District would ordinarily be expected to apply to the Licensing Authority in which their operating premises are based.
- 10.3 Only a 'complete' application will be accepted for processing so the applicant will need to ensure that all the correct documents are returned to the Council.
- 10.4 Applicants should ensure that they obtain any necessary planning consents relating to the use of premises in connection with the operation of a business.
- 10.5 Any driver who receives bookings or has contracts for the hire and reward for a Private Hire vehicle is required to hold an operator's licence. The application must be accompanied with a list of vehicles and drivers used by the operator. An operator must be a 'fit and proper person' and is therefore subject to a DBS check.
- 10.6 The applicant for the grant of a new licence will need to obtain a DBS as an aid to establishing if an applicant is a suitable person to hold an operator's licence. If a Private Hire Drivers or combined licence is held an additional DBS check will not be necessary unless the DBS is out of date. (i.e. older than 3 years).
- 10.7 As the DBS can only check police records for the duration of a person's residency in the United Kingdom, it is necessary for first time applicants that have previously lived abroad to provide the Council with a copy of their police record or a certificate of good conduct through the appropriate embassy or consulate of those countries in which they have resided.
- 10.8 Both the current DBS disclosure information and a police record or certificate of good conduct from the appropriate country(ies) are necessary to determine an applicant's fit and proper status to be granted a Private Hire operator's licence.
- 10.9 If the necessary certificate of good conduct or a copy of an applicant's police record whilst he/she were resident outside the UK cannot be provided, written confirmation must be provided to the Council, stating the reasons why the information has not been made available from the appropriate authorities and including any available supporting documentary evidence as to why this is so.
- 10.10 An Operator must not include in the business trading title any reference to 'CAB' or 'TAXI'.
- 10.11 The operator's licence must be produced on request of an Authorised Officer of the Council or a Police Officer on request.
- 10.12 An Operator must ensure that any telephone facilities and radio equipment provided are maintained in a sound condition and that any defects are repaired promptly.

- 10.13 An Operator shall undertake to ensure that all drivers and vehicles owned, controlled or operated by them shall be licensed and comply with all the conditions of their driver's licence and / or Private Hire Vehicle licence.
- 10.14 All Operators must maintain a reasonable standard of behaviour in their dealings with the general public, other licensed operators, proprietors, and drivers of licensed vehicles and Authorised Officers of the Council.
- 10.15 All Operators shall provide assistance necessary for carrying out the functions of the appropriate legislation to an Authorised Officer and any person accompanying the Authorised Officer.
- 10.16 A Private Hire Licence is NOT needed:
- 1) For a vehicle while it is being used in connection with a funeral or for a vehicle used wholly or mainly, by a funeral director, for funerals;
 - 2) For a vehicle while it is being used in connection with a wedding;
- 10.17 The Council's advice is that in all other cases of carrying passengers for hire or reward a licence is needed.
- 10.18 An Operator must ensure that all vehicles and drivers working for them are licensed by The District Council.
- 10.19 When a new driver begins to work under the control of an operator, and when an existing driver leaves, the operator must inform the District Council in writing of that change within 7 days.
- 10.20 An Operator must keep records of bookings and produce these to an authorised officer or police officer on request. The content of these will be as prescribed by the District Council.
- 10.21 An operator must, if possible, accept a booking for a Private Hire vehicle if the booking is requested by or on behalf of a disabled person, or a person who wishes a disabled person to accompany him/her.
- 10.22 An operator cannot make an additional charge for the carriage of an assistance dog.
- 10.23 An Operator shall record details of every private hire booking made by him / her. The following information shall be recorded in an easily retrievable method (e.g. computer database or page numbered log) before the commencement of each journey, and shall include the following:
- the date and time of each booking;
 - how the booking was received, i.e. telephone or personal call;
 - the time of pick-up;
 - where journey was from and to;
 - the name, address and contact telephone number of the hirer;
 - the private hire vehicle licence plate number of the vehicle allocated the booking;
 - the name of the driver allocated the booking.

- 10.24 In addition to the requirement of Condition 10.23 above, an operator of a special event vehicle must also record the nature of the special event i.e. why was a special event vehicle booked
- 10.25 The records shall be kept for a period of three years, or such longer period as is required by an Authorised Officer of the District Council.
- 10.26 The records shall be produced, on request, to any Police Officer or Authorised Officer of the Council.
- 10.27 An Operator shall maintain at his premises details of all vehicles operated by him, which shall include the following:
- the registration number of the vehicle;
 - the number of the identification plate provided by the Council pursuant to Section 48(5) of the 1976 Act;
 - the name and address of the proprietors of the vehicle;
 - the name(s) and address(es) of the driver(s) of the vehicles(s);
 - the badge number(s) of the driver(s) as issued by the Council;
 - any radio call sign used in connection with the vehicle;
 - the date the operator started to use the vehicle and the date the operator ceased to use the vehicle;
 - comments and remarks

The above records shall be produced on request to any Authorised Officer of the District Council or Police Officer.

- 10.28 All vehicle and driver records kept by the operator shall be kept for a period not less than six months following the date of the last entry.
- 10.29 Private Hire operators must maintain a written or computer record for each vehicle operating under their auspice and enter into this record information, which will include such information as: renewal dates for insurance, MOTs, DVLA car tax, details of accidents, etc.
- 10, 30 Vehicles must be inspected at least once a week by the operator or a member of their staff and any defects or damage noted on the record, the remedial action required, date the Council was informed and date the action was completed.

Standard of Service

- 10.31 The operator shall provide a prompt, efficient and reliable service to members of the public at all times.
- 10.32 The operator shall ensure that when a vehicle has been hired to be in attendance at an appointed time and place, the vehicle shall, unless delayed or prevented by sufficient cause, punctually attend at that appointed time and place.
- 10.33 The operator must keep clean, adequately heated, ventilated and lit any premises which the operator provides and to which the public have access, whether for the purpose of booking or waiting.
- 10.34 The operator must ensure that any waiting area provided by the operator has seating facilities.

- 10.35 The operator shall ensure that any telephone facilities and radio equipment provided are maintained in a sound condition and that any defects are repaired promptly.
- 10.36 The operator shall maintain a log detailing any complaints received from customers which shall be available for inspection by any Authorised Officer upon request. The log must provide the complainant's name/address/complaint details and any action taken against driver/vehicle proprietor.
- 10.37 The operator must have suitable insurance policy (ies) in place to allow them to carry out their business legally.
- 10.38 The operator must carry out a health and safety risk assessment. This risk assessment must be published and a copy supplied to the Council, the policy must be reviewed on a regular basis or when there are significant changes in the operators business.
- 10.39 The operator must display a copy of the Fenland District Council operator's licence in a prominent position at operating premises he or she may have.
- 10.40 No operator shall invite or accept a private hire vehicle booking or control or arrange a journey to be undertaken by a private hire vehicle without first making available the charge for the hire of the vehicle to the person making the booking. The charge can be notified in writing or verbally.

Change of Address

- 10.41 The operator shall notify the District Council in writing of any change of his/her name, address (including any address from which he operates or otherwise conducts his business as an operator) during the period of the licence within seven days of such change taking place.
- 10.42 The existing licence must be returned to the Council, together with the appropriate fee, for the licence to be duly amended and re-issued.

Convictions

- 10.43 The operator shall within seven (7) days notify the Council, in writing, of convictions of any kind imposed on him/her (or if the operator is a company, any convictions imposed on the company) during the period of the licence, giving particulars of the date and place of conviction, the nature of the charge and penalty imposed together with such further information concerning the offence as the Council may require.
- 10.44 Depending on the circumstances or the number of penalty points accrued on their DVLA driver's licence (if held), operators may be referred to the Licensing Panel. In doing so, the Panel must have regard to all convictions, police cautions, charges driving convictions, complaint acceptable conduct/behaviour, breach of licence conditions and other convictions obtained during the course of a licence.
- 10.45 Operators should be aware that if they fail to comply with this requirement it may prevent the Council from renewing their licence under delegated authority.

Drivers and Other Staff

- 10.46 If a driver is permitted or employed to drive a licensed vehicle by a Private Hire operator he shall, before commencing to drive that vehicle, deposit his/her driver's licence with that operator for retention by him/her until such time as the driver ceases to be permitted or employed to drive for that operator when the driver's licence must be returned to the driver.
- 10.47 Operators must ensure that all drivers are licensed and comply with the conditions of that licence.
- 10.48 Operators must ensure that all drivers are in possession of a valid full driving licence issued by the DVLA or a licence from an EEA or EU state.
- 10.49 Operators must ensure that the DVLA, EEA or EU driving licence shows the driver's current home address.
- 10.50 Operators must ensure that the DVLA, EEA or EU driving licence covers the appropriate category for the vehicle being driven.
- 10.51 Operators must ensure that any licensed vehicle parked on a public highway at or in the vicinity of the operator's premises shall do so in a legal manner, vehicles shall not be left unattended on yellow lines or other restrictive road markings when those restrictions are in force. Vehicles shall not cause an obstruction or cause a nuisance in the vicinity of the operating base.
- 10.52 The operator shall ensure that they comply with all legislation regarding the employment of staff, Health and Safety, etc., and provide adequate staff facilities.
- 10.53 Operators must ensure that:
- a. the vehicle is operated in accordance with Fenland District Council's conditions;
 - b. the vehicle is correctly insured as required by the relevant Road Traffic Regulation Act or any other enactment;
 - c. the licensed vehicle is displaying a current vehicle excise tax disc;
 - d. the vehicle is regularly inspected to ensure that it is in a fit and proper condition to be used as a licensed vehicle
 - e. the Council is notified in writing within seventy-two (72) hours of any accident and/or vehicle damage.
- 10.54 Depending on the circumstances or the number of penalty points accrued on their DVLA driver's licence (if held), operators may be referred to a Licensing Panel. In doing so, the Panel must have regard to all convictions, police cautions, charges, driving convictions, complaints of unacceptable conduct/behaviour, breach of licence conditions and other convictions obtained during the course of a Licence.
- 10.55 Operators should be aware that if they fail to comply with condition 10.54 above, it may prevent the District Council from renewing their licence under delegated authority.

10.56 Operators must ensure that non-licensed staff, i.e. controllers, cleaners etc behave in a civilised and appropriate manner when involved in the operation of the business. This includes discussion on social media sites.

Penalties

10.57 The Local Government (Miscellaneous Provisions) Act 1976 provides that any person who acts in contravention of the provisions of Part II of the Act shall be guilty of an offence and liable on summary conviction to a fine not exceeding level 3 on the standard scale. In addition such action, whether or not resulting in criminal proceedings being taken, may lead to the suspension or revocation of an existing licence or refusal to renew such a licence.

11.0 Enforcement

- 11.01 The District Council has a responsibility as the 'Enforcement Agency' of the drivers, vehicles and operators it has licensed. Enforcement covers offences related to current legislation, drivers' behaviour, the condition of the vehicles and the investigation of complaints made by the public against any licence holder.
- 11.02 The District Council can suspend or revoke licences and take Court action where criminal offences have been committed, as necessary, against licence holders.
- 11.03 Licensing and enforcement are carried out by District Council officers appointed as 'Authorised Officers' for that purpose. Authorised Officers are issued with an identity badge and the written authority to carry out their enforcement duties.
- 11.04 The District Council recognises the fact that licensing is not to be the sole or only means of addressing problems or issues connected with the taxi trade. Other mechanisms include:
- a. Planning controls
 - b. Bylaws, conditions and statutory instruments
 - c. Police powers to enforce the law
 - d. Highways management
 - e. Vehicle Inspectorate.
- 11.05 Enforcement will be carried out to identify and prevent breaches of legislation or licence conditions. Any enforcement action will be determined on a risk basis by the District Council and its partner agencies and resources will be concentrated on areas perceived as having the greatest need.
- 11.06 Inspections will include the vehicle, operator and driver. Driver inspections will, on occasions, include the use of breath testing equipment to detect excess alcohol. This will be carried out by the Police with an Authorised Officer of the District Council present.
- 11.07 All enforcement actions and decisions will be in line with Fenland District Council's Enforcement Policy, Prosecution Policy, Enforcement Concordat and the Code for Crown Prosecutors.

Enforcement Action

- 11.08 The following enforcement action may be taken.
- a. No action
 - b. Informal action i.e. written and/or verbal warnings
 - c. Formal cautions
 - d. Penalty points
 - e. Statutory notices (stop notices etc.)
 - f. Suspension of a licence
 - g. Revocation of a licence
 - h. Prosecution.
- 11.09 The Licensing Team may need to interview the individual to enable information to be gathered to make the correct decision.

Referral to the Licensing Committee

- 11.10 Where an applicant or an existing driver or operator is referred to the Licensing Committee for consideration, he/she will be notified in writing of the reason and the date, time and venue of the Committee hearing.
- 11.11 They will be advised that they may bring a representative to the hearing. The representative may be a friend, legal representative or a representative from the trade whom they wish to assist them in addressing the Committee. It is suggested that consultation with a representative should take place in advance of the hearing date to ensure that cases are well prepared for Committee consideration.

The Licensing Sub-Committee

- 11.12 A Licensing Sub-Committee consisting of three members of the Council's Licensing Committee made up of District Councillors from outside the ward in which the applicant or existing driver or operator lives will be appointed for the hearing. A chairman is appointed to supervise the Committee during the hearing process. The Committee is advised by a legal representative.
- 11.13 District Council officers will attend the hearing in an advisory capacity, but do not take part in the decision making process.
- 11.14 A number of applications and disciplinary matters could be considered on the day. Each matter will be considered in a confidential manner and the public and other applicants will not usually have access to the meeting.

The Decision

- 11.15 The Committee may come to a number of different conclusions:
- a. Grant or refuse application
 - b. Take no action
 - c. Issue a verbal warning
 - d. Suspend or revoke a licence
 - e. Apply additional conditions to a licence.

Right of Appeal

- 11.16 If the Committee decides to refuse the grant of a vehicle, operator or driver's licence, or in the case of a disciplinary hearing, decides to suspend or revoke a driver's or operator's licence, the person will have the right of appeal to a Magistrates' Court.
- 11.17 In the case of refusal to grant a Hackney Carriage vehicle licence, appeal will be to the Crown Court.

Licence Renewal Reminders

- 11.18 please note the responsibility for renewals rests with the licensee. Renewal applications for vehicle licences can be made 28 days before the old licence expires.

- 11.19 If a licence lapses for any reason then any subsequent application will be treated as a new application.
- 11.20 Whilst every effort will be made to issue licences within the given time frames, the council cannot be held responsible for delays experienced through failure by outside agencies to respond within those time frames.
- 11.21 The authority will not issue licences on demand, but will in exceptional circumstances make every effort to ensure continuity of service.

FENLAND DISTRICT COUNCIL

BYELAWS

Made under

Section 68 of the Town Police Clauses Act 1847

And under

Section 171 of the Public Health Act 1875

By the

Fenland District Council

With respect to

Hackney Carriages

BYELAWS

Made under Section 68 of the Town Police Clauses Act, 1847, and Section 171 of the Public Health Act, 1875, by the Fenland District Council with respect to hackney carriages in Fenland District.

Interpretation

- 1) Throughout these byelaws “the Council” means the District Council of Fenland and “the District” means Fenland District.

Provisions regulating the manner in which the number of each hackney carriage corresponding with the number of its licence shall be displayed.

- 2)
 - a) The proprietor of a hackney carriage shall cause the number of the licence granted to him in respect of the carriage to be legibly painted or marked on the outside and inside of the carriage, or on plates affixed thereto;
 - b) A proprietor or driver of a hackney carriage shall;
 - i not wilfully or negligently cause or suffer any such number to be concealed from public view while the carriage is standing or plying for hire;
 - ii not cause or permit the carriage to stand or ply for hire with any such painting, marking or plate so defaced that any figure or material particular is illegible.

Provisions regulating how hackney carriages are to be furnished or provided

- 3) The proprietor of a hackney carriage shall;
 - a) provide sufficient means by which any person in the carriage may communicate with the driver;
 - b) cause the roof or covering to be kept water-tight;
 - c) provide any necessary windows and means of opening and closing not less than one window on each side;
 - d) cause the seats to be properly cushioned or covered;
 - e) cause the floor to be provided with a proper carpet, mat, or other suitable covering;
 - f) cause the fittings and furniture generally to be kept in a clean condition, well maintained and in every way fit for public service;
 - g) provide means for securing luggage if the carriage is so constructed as to carry luggage;
 - h) provide an efficient fire extinguisher which shall be carried in such a position as to be readily available for use;

- i) provide at least two doors for the use of persons conveyed in such a separate means of ingress and egress for the driver.
- 4) (1) The proprietor of a hackney carriage shall cause any taximeter, with which the carriage is provided to be so constructed, attached, and maintained as to comply with the following requirements, that is to say:
- a) the taximeter shall be fitted with a key, flag, or other device the operation of which will bring the machinery of the taximeter into action and cause the word "HIRED" to appear on the face of the taximeter;
 - b) such key, flag or other device shall be capable of being locked in such a position that the machinery of the taximeter is not in action and that no fare is recorded on the face of the taximeter;
 - c) when the machinery of the taximeter is in action there shall be recorded on the face of the taximeter in clearly legible figures a fare not exceeding the rate or fare which the proprietor or driver is entitled to demand and take for the hire of the carriage by distance in pursuance of the tariff fixed by the Council in that behalf;
 - d) the word "FARE" shall be printed on the face of the taximeter in plain letters so as clearly to apply to the fare recorded thereon;
 - e) the taximeter shall be so placed that all letters and figures on the face thereof are at all times plainly visible to any person being conveyed in the carriage, and for that purpose the letters and figures shall be capable of being suitably illuminated during any period of hiring;
 - f) the taximeter and all the fittings thereof shall be so affixed to the carriage with seals or other appliances that it shall not be practicable for any person to tamper with them except by breaking, damaging or permanently displacing the seals or other appliances.

Provisions regulating the conduct of the proprietors and drivers of hackney carriages plying within the district in their several employments, and determining whether such drivers shall wear any and what badges.

- 5) The driver of a hackney carriage provided with a taximeter shall:-
- a) when standing or plying for hire, keep the key, flag or other device fitted in pursuance of the byelaw in that behalf locked in the position in which no fare is recorded on the face of the taximeter;
 - b) before beginning a journey for which a fare is charged for distance and time, bring the machinery of the taximeter into action by moving the said key, flag or other device, so that the word "HIRED" is legible on the face of the taximeter and keep the machinery of the taximeter in action until the termination of the hiring;
 - c) cause the dial of the taximeter to be kept properly illuminated throughout any part of the hiring which is during the hours of darkness; this being the time between half-an-hour after sunset to half-an-hour before sunrise, and also at any other time at the request of the hirer.

- 6) A proprietor or driver of a hackney carriage shall not tamper with or permit any person to tamper with any taximeter with which the carriage is provided, with the fittings thereof or with the seals affixed thereto.
- 7) Every proprietor of a hackney carriage not provided with a taximeter fitted with a flag or other device bearing the words "for hire" shall cause the carriage to be provided with a sign so constructed as to comply with the following requirements, that is to say:
 - a) the sign shall bear the words "For Hire" in plain letters at least one and a half inches in height and
 - b) the sign shall be capable of being so operated that it indicates clearly and conveniently to persons outside the carriage whether or not the vehicle is for hire.
- 8) The driver of a hackney carriage provided with a sign in pursuance of Byelaw 7 shall
 - a) when standing, or plying for hire, operate the sign so that the words "For Hire" is clearly and conveniently legible by persons outside the carriage;
 - b) as soon as the carriage is hired, whether by distance or by time, operate the said sign so that the words "For Hire" are not conveniently legible to persons outside the carriage.
- 9) the driver of a hackney carriage shall, when plying for hire in any street and not actually hired,
 - a) where appropriate proceed with reasonable speed to one of the stands fixed by the Council, where appropriate, in that behalf except that in March the driver shall not station the carriage in the stand if the other two places in the stand are occupied by carriages owned by his firm or by the firm for which he is driving;
 - b) on arriving at a stand in Wisbech not already occupied by the full number of carriages authorised to occupy it, station the carriage immediately behind the carriage or carriages on the stand and so as to face in the same direction;
 - c) in respect of b) above from time to time when any other carriage immediately in front is driven off or moved forward cause his carriage to be moved forward so as to fill the place previously occupied by the carriage driven off or moved forward.
- 10) a proprietor or driver of a hackney carriage, when standing or plying for hire, shall not, by calling out or otherwise, importune any person to hire such carriage and shall not make use of the services of any other person for the purpose.
- 11) The driver of a hackney carriage shall behave in a civil and orderly manner and shall take all reasonable precautions to ensure the safety of persons conveyed in or entering or alighting from the vehicle.
- 12) The proprietor or driver of a hackney carriage who has agreed or has been hired to be in attendance with the carriage at an appointed time and place shall, unless delayed or prevented by some sufficient cause, punctually attend with such carriage at such appointed time and place.

- 13) A proprietor or driver of a hackney carriage shall not convey or permit to be conveyed in such carriage any greater number of persons than the number of persons specified on the plate affixed to the outside of the carriage.
- 14) If a badge has been provided by the Council and delivered to the driver of a hackney carriage he shall, when standing or plying for hire, and when, hired, wear that badge in such position and manner as to be plainly visible.
- 15) The driver of a hackney carriage so constructed as to carry luggage shall, when requested by any person hiring or seeking to hire the carriage,
 - a. convey a reasonable quantity of luggage;
 - b. afford reasonable assistance in loading and unloading;
 - c. affords reasonable assistance in removing it to or from the entrance of any building, station, or place at which he may take up or set down such person.

Provisions fixing the rates or fares to be paid for hackney carriages within the district, and securing the due publication of such fares

- 16) The proprietor or driver of a hackney carriage shall be entitled to demand and take for the hire of the carriage the rate or fare prescribed by the Council the rate or fare being calculated by distance unless the hirer express at the commencement of the hiring his desire to engage by time.

Provided always that where a hackney carriage furnished with a taximeter shall be hired by distance the proprietor or driver thereof shall not be entitled to demand and take a fare greater than that recorded on the face of the taximeter, save for any extra charges authorised by the Council which it may not be possible to record on the face of the taximeter.

- 17)
 - a. The proprietor of a hackney carriage shall cause a statement of the fares fixed by the Council in that behalf to be exhibited inside the carriage, in clearly distinguishable letters and figures.
 - b. The proprietor or driver of a hackney carriage bearing a statement of fares in accordance with this byelaw shall not wilfully or negligently cause or suffer the letters or figures in the statement to be concealed or rendered illegible at any time while the carriage is plying or being used for hire.

Provisions securing the safe custody and re-delivery of any property accidentally left in hackney carriages, and fixing the charges to be made in respect thereof

- 18) The proprietor or driver of a hackney carriage shall immediately after the termination of any hiring or as soon as practicable thereafter carefully search the carriage for any property which may have been accidentally left therein.
- 19) The proprietor or driver of a hackney carriage shall, if any property accidentally left therein by any person who may have been conveyed in the carriage be found by or handed to him,

- a. carries it as soon as possible and in any event within 48 hours, if not sooner claimed by or on behalf of its owner, to the office of the Council, and leave it in the custody of the officer in charge of the office on his giving a receipt for it.
- b. is entitled to receive from any person to whom the property shall be re-delivered an amount equal to five pence in the pound of its estimated value (or the fare for the distance from the place of finding to the office of the Council, whichever be the greater) but not more than five pounds.

Penalties

- 20) Every person who shall offend against any of these byelaws shall be liable on summary conviction to a fine not exceeding one hundred pounds and in the case of a continuing offence to a further fine not exceeding five pounds for each day during which the offence continues after conviction thereafter.

Repeal of Byelaws

- 21) The byelaws relating to hackney carriages which were made by the Council on the 20th day of August 1976 and which were confirmed by on of her Majesty's Principal Secretaries of State on the 1st day of October, 1976 are hereby repealed.

The Common Seal of the Fenland District Council was affixed hereto this

(signed) E. S. THOMPSON
Chief Executive

12.0 Penalty Points System

12.1 Authorised Officers of the District Council can impose penalty points on drivers of private hire vehicles and hackney carriages, proprietors of vehicles and operators of private hire vehicles as shown below. This system is designed for the interest of the public as an aid to ensure continued public safety and to give the individual concerned a chance to rectify any relatively minor breaches of licence conditions without the need to resort to suspension, revocation or prosecution.

12.2 If an individual concerned accrues a total of 12 points in any 12 month period then he/she will automatically be referred to a Licensing Panel with a request that the Panel review the individual's continued suitability to hold a licence.

12.3 The following list, whilst not exhaustive, details the circumstances in which a licence holder will be directly referred to a Panel.

- Providing false or misleading information on licence application form, or failing to provide relevant information including any convictions imposed;
- Authorised officer refused access to operator/driver records;
- Carrying excess passengers;
- Abusive or obstructive behaviour (verbal or physical) to authorised officers of the Council or police officers;
- Using a vehicle for which the licence has been suspended or revoked;
- Carrying an offensive weapon in the vehicle;
- Driver not holding a current DVLA licence;
- Nine or more penalty points on a DVLA driving licence;
- Convictions including motoring convictions for:
 - Drinking/drugs and driving;
 - Causing death by careless driving;
 - Reckless/dangerous driving;
 - Offences resulting in disqualification;
 - Disqualified from holding a licence until driving test passed.

12.4 The following list, whilst not exhaustive, details the number of penalty points that will be awarded for the infringements shown:

BC Code	Infringement	Penalty Points
PP1	Failing to notify the Licensing team, in writing of charges, summons, penalty points etc	4
PP2	Displaying any feature on a private hire vehicle which would suggest it is a taxi	4
PP3	Failure to attend the Council Offices when directed by an authorised officer.	6
PP4	Failure to carry an assistance dog without requisite exemption	6

BC Code	Infringement	Penalty Points
PP5	Failure to notify the Licensing Office of any change in medical fitness to drive.	4
PP6	Failure to notify transfer of vehicle within prescribed time limit	4
PP7	Failure to produce a valid insurance certificate/cover note within 7 days of request.	6
PP8	Failure to produce the 6 monthly MOT/Compliance check	4
PP9	Failure to report to the authority the transfer of a private hire vehicle licence or a hackney carriage proprietors licence within 14 days of transfer.	4
PP10	Failure to return vehicle licence plate within 7 days after due notice following expiry, revocation or suspension of such licence	4
PP11	Leaving a vehicle unattended on the rank.	4
PP12	Licensed vehicle not carrying a spare wheel, space saver or tyre weld that is capable of being used.	4
PP13	Private hire drivers touting	6
PP14	Private Hire Operator failing to maintain their records in the correct format.	6
PP15	Failing to notify Licensing Team of a change in private hire operator.	4
PP16	Wheelchair accessible hackney carriage fails to carry ramps for loading disabled persons wheelchair	6
PP17	Conviction for minor traffic offences e.g. obstruction, waiting in a restricted street, speeding etc.	3
PP18	Driver smoking in the vehicle	3
PP19	Failing to deal with lost property in the correct manner.	3
PP20	Failing to display fare card (hackney carriage)	3
PP21	Failing to have a Private Hire Driver or Hackney Carriage Driver badge in his possession whilst driving a licensed vehicle.	3
PP22	Failing to notify the Licensing Office in writing, of being involved in an accident within 72 hours of the accident occurring.	3
PP23	Failing to notify the Licensing team, in writing, of a change of address within 7 days.	3
PP24	Failure to display any Plates, Signs or Notices required by the Council	3
PP25	Failure to display official 'no smoking' sign in vehicle	3
PP26	Licensed vehicle displaying unauthorised markings (inside or out)	3

BC Code	Infringement	Penalty Points
PP27	Not having an appropriate Fire Extinguisher and/or first aid kit in the vehicle.	3
PP28	Parking/stopping contrary to authorised road markings	3
PP29	Parking/stopping with one or more wheels on the pavement	3
PP30	Sounding the vehicle horn to announce arrival or tout for business	3
PP31	Unreasonable prolongation of journeys or any misconduct regarding the charging of fares	3
PP32	Using a mobile phone, radio hand set, eating or drinking whilst the vehicle is in motion	3
PP33	Failure to comply with, or commit an offence under any Road Traffic legislation, including Road Traffic Act 1988, Road Traffic Offenders Act 1988 or Road Traffic Regulation Act 1984.	3
PP34	Defective vehicle, i.e. bald tyre, headlight not working	4
PP35	Failure to comply with legislation pertaining to hackney carriage and private hire licensing.	3-6

13.0 Summary of Offences

TOWN POLICE CLAUSES ACT 1847

<u>Section</u>	<u>Offence</u>
40	Giving false information on application for hackney carriage proprietor's licence
44	Failure to notify change of address of hackney carriage proprietor
45	Plying for hire without a hackney carriage proprietor's licence
47	Driving a hackney carriage without a hackney carriage driver's licence
47	Lending or parting with a hackney carriage driver's licence
47	Hackney carriage proprietor employing unlicensed driver
48	Failure by hackney carriage proprietor to hold hackney carriage driver's licence
48	Failure by hackney carriage proprietor to produce hackney carriage driver's licence
52	Failure to display hackney carriage plate
53	Refusal to take a fare
54	Charging more than the agreed fare
55	Obtaining more than the legal fare
56	Travelling less than the lawful distance for an agreed fare
57	Failing to wait after a deposit to wait has been paid
58	Charging more than the legal fare
59	Carrying other person than the hirer without consent
60	Driving a hackney carriage without proprietor's consent
60	Person allowing another to drive a hackney carriage without proprietor's consent
61	Drunken driving of hackney carriage
61	Wanton or furious driving or wilful misconduct leading to injury or danger
62	Driver leaving hackney carriage unattended
64	Hackney carriage driver obstructing other hackney carriages

14.0 HACKNEY CARRIAGE PROVISIONS

LOCAL GOVERNMENT (MISCELLANEOUS PROVISIONS) ACT 1976

<u>Section</u>	<u>Offence</u>
49	Failure to notify transfer of hackney carriage proprietor's licence
50(1)	Failure to present hackney carriage for inspection as required
50(2)	Failure to inform Local Authority where hackney carriage is stored if requested
50(3)	Failure to report an accident to Local Authority
50(4)	Failure to produce hackney carriage proprietor's licence and insurance certificate
53(3)	Failure to produce hackney carriage driver's licence
57	Making false statement or withholding information to obtain hackney carriage driver's licence
58(2)	Failure to return plate after notice given after expiry, revocation or suspension of hackney carriage proprietor's licence
61(2)	Failure to surrender driver's licence after suspension, revocation or refusal to renew
64	Permitting any vehicle other than hackney carriage to wait on a hackney carriage stand
66	Charging more than the meter fare for a journey ending outside the district, without prior agreement
67	Charging more than the meter fare when hackney carriage used as private hire vehicle
69	Unnecessarily prolonging a journey
71	Interfering with a taximeter
73(1)(a)	Obstruction of authorised officer or constable
73(1)(b)	Failure to comply with requirement of authorised officer or constable
73(1)(c)	Failure to give information or assistance to authorised officer or constable

15.0 PRIVATE HIRE PROVISIONS

LOCAL GOVERNMENT (MISCELLANEOUS PROVISIONS) ACT 1976

<u>Section</u>	<u>Offence</u>
46(1)(b)	Driving a private hire vehicle without a private hire driver's licence
46(1)(c)	Proprietor of a private hire vehicle using an unlicensed driver
46(1)(d)	Operating a private hire vehicle without a private hire operator's licence
46(1)(e)	Operating a vehicle as a private hire vehicle when the vehicle is not licensed as a private hire vehicle
46(1)(e)	Operating a private hire vehicle when the driver is not licensed as a private hire driver
48(6)	Failure to display private hire vehicle plate
49	Failure to notify transfer of private hire vehicle licence
50(1)	Failure to present private hire vehicle for inspection as required
50(2)	Failure to inform local authority where private hire vehicle is stored if requested
50(3)	Failure to report an accident to local authority
50(4)	Failure to produce private hire vehicle licence and insurance certificate
53(3)	Failure to produce private hire driver's licence
54(2)	Failure to wear private hire driver's badge
56(2)	Failure by private hire operator to keep records of bookings
56(3)	Failure by private hire operator to keep records of private hire vehicles operated by him
56(4)	Failure to produce private hire operator's licence on request
57	Making false statement or withholding information to obtain private hire driver's or operator's licence
58(2)	Failure to return plate after notice given after expiry, revocation or suspension of private hire vehicle licence
61(2)	Failure to surrender driver's licence after suspension, revocation or refusal to renew
67	Charging more than the meter fare when hackney carriage used as private hire vehicle
69	Unnecessarily prolonging a journey
71	Interfering with a taximeter
73(1)(a)	Obstruction of authorised officer or constable
73(1)(b)	Failure to comply with requirement of authorised officer or constable
73(1)(c)	Failure to give information or assistance to authorised officer or constable

Proposed Relevance of Convictions Hackney Carriage & Private Hire Licensing

1. Introduction

1.1 The purpose of these guidelines is to provide guidance on the criteria taken into account by the Council when determining whether or not an applicant or an existing licence holder is a fit and proper person to hold a hackney carriage and/or private hire driver or operator licence.

1.2 The overriding aim of the licensing authority is to protect the safety of the public.

The licensing authority is concerned to ensure:

- That a person is a fit and proper and safe and suitable person.
- That the person does not pose a threat to the public.
- That the public are safeguarded from dishonest persons.
- The safeguarding of children, vulnerable and young persons.

1.3 This document provides guidance to any person with an interest in taxi and private hire licensing. In particular, but not exclusively:

- Applicants for Drivers' licences.
- Existing Licensed Drivers whose licences are being reviewed.
- Applicants for Private Hire Operator licenses.
- Licensing Officers.
- Members of the Licensing Panel
- Magistrates hearing appeals against Local Authority decisions.

1.4 Where Licensing Officers have delegated powers to grant licences, they will utilise these guidelines when making a decision to grant a licence. In all other cases applications for licences will be referred to the Licensing Panel. Whilst Officers and the Panel will have regard to the guidelines contained in the policy, **each case will be considered on its individual merits and, where the circumstances demand, the Panel/Officer may depart from the guidelines.**

2. General guidelines

2.1 There may be occasions where it is appropriate to depart from the guidelines, for example where the offence is a one-off occasion or there are mitigating circumstances or alternatively where there are many or continuous offences which may show a pattern of offending and unfitness.

2.2 A person with a conviction for a serious offence need not be automatically barred from obtaining a licence, but would normally be expected to:

- (a) Remain free of conviction for an appropriate period; and
- (b) Show adequate evidence that he or she is a fit and proper person to hold

a licence (the onus is on the applicant to produce such evidence). Simply remaining free of conviction may not generally be regarded as adequate evidence that a person is a fit and proper person to hold a licence.

Where an applicant has been convicted of a criminal offence, the licensing authority cannot review the merits of the conviction [Nottingham City Council v. Mohammed Farooq (1998)].

3. Appeals

- 3.1 Any applicant refused a driver's licence on the grounds that the licensing authority is not satisfied he/she is a fit and proper person to hold such a licence has a right to appeal to the Magistrates' Court within 21 days of receipt of the notice of refusal [Local Government Miscellaneous Provisions Act 1976, s 77 (1)].

4. Powers

- 4.1 Section 61 and Section 62 of the Local Government Miscellaneous Provisions Act 1976 allow the licensing authority to suspend, revoke or refuse to renew a licence if the applicant/licence holder has been convicted of an offence involving dishonesty, indecency, violence; failure to comply with the provisions of the Town Police Clauses Act 1847; failure to comply with the provisions of Part II of the Local Government (Miscellaneous Provisions) Act 1976; or any other reasonable cause.
- 4.2 The Rehabilitation of Offenders Act 1974 (Exceptions)(Amendment) Order 2002, allows the licensing authority to take into account all convictions recorded against an applicant or the holder of a private hire vehicle or hackney carriage driver's licence, whether spent or not. Therefore the licensing authority will have regard to all relevant convictions, particularly where there is a long history of offending or a recent pattern of repeat offending.
- 4.3 In this policy the term "disqualification" refers to the period served. In order to take account of the fact that a court may reduce the period of disqualification from driving, an applicant must provide evidence in advance to prove that the court agreed a reduction in the period of disqualification.
- 4.4 It should be noted that "any reasonable cause" includes conduct falling short of a criminal conviction(s).

5. Consideration of disclosed criminal history

- 5.1 Under the provisions of Sections 51, 55, and 59, Local Government (Miscellaneous Provisions) Act 1976, the licensing authority is required to ensure that an applicant for the grant or renewal of a hackney carriage and/or a private hire vehicle drivers' licence and/or private hire vehicle operator's licence is a 'fit and proper' person to hold such a licence. However, if an applicant has any convictions, warnings, cautions or charges awaiting trial, the licensing authority will look into:

- How relevant the offence(s) are to the licence being applied for.
- How serious the offence(s) were.
- When the offence(s) were committed.
- The date of conviction.
- Circumstances of the individual concerned.
- Sentence imposed by the court.
- The applicant's age at the time of conviction.
- Whether they form part of a pattern of offending.
- Any other character check considered reasonable (e.g. personal references).
- Any other factors that might be relevant.

- 5.2 Existing holders of driver licences are required to notify the licensing authority in writing within seven days of receiving a driving licence endorsement, fixed penalty notice or criminal conviction (including cautions).
- 5.3 Applicants can discuss further what effect a caution/conviction may have on any application by contacting the Licensing Team in confidence for advice.
- 5.4 The licensing authority is also entitled to use other records and information that may be available to it in determining applications or an entitlement to continue holding a licence. This may include information held by the licensing authority or other licensing authorities, and information disclosed by the police or other agencies.
- 5.5 It is an offence for any person knowingly or recklessly to make a false declaration or to omit any material particular in giving information required by the application for a licence. Where an applicant has made a false statement or a false declaration on their application for the grant or renewal of a licence, the licence will normally be refused.
- 5.6 It should be noted that the determination of whether an applicant is “fit and proper” or safe and suitable includes consideration of conduct falling short of a criminal conviction.

6. Offences involving violence, disorder and damage to property

- 6.1 Licensed drivers have close regular contact with the public. A firm line is to be taken with those who have convictions for offences involving violence, disorder or criminal damage. An application will normally be refused if the applicant has a conviction for an offence that involved the loss of life.
- 6.2 Any one with a conviction for an offence involving violence, disorder or damage to property will normally be expected to remain free of such convictions for a period of at least 3 years. However, given the range of the offences, consideration must be given to the nature of the conviction. A licence will not normally be granted if an applicant has more than one conviction in the last 10 years for an offence involving violence or disorder.
- 6.3 In the most serious cases, an application will be refused unless there are exceptional circumstances. A licence will not normally be granted where the applicant has a conviction for an offence such as:
- Murder.
 - Manslaughter.
 - Manslaughter or culpable homicide while driving.
 - Terrorism offences.
 - Or any similar offences (including attempted or conspiracy to commit) or any offences which replace the above.
- 6.4 An application will normally be refused if the applicant has a conviction for an offence or similar offence(s) which replace the offences below and the conviction is less than 10 years prior to the date on which the application is determined by the authority:
- Arson.
 - Malicious wounding or grievous bodily harm.
 - Actual bodily harm.
 - Grievous bodily harm with intent.
 - Robbery.

- Possession of firearm.
- Riot.
- Violent disorder.
- Any similar offences (including attempted or conspiracy to commit) or any offences which replace the above.

6.5 An application will normally be refused if the applicant has a conviction for an offence or similar offence(s) which replace the offences below and the conviction is less than 5 years prior to the date on which the application is determined by the authority:

- Common assault.
- Assault occasioning actual bodily harm.
- Affray.
- Aggravated criminal damage.
- Any racially aggravated offence.
- Resisting arrest.
- Assault police.
- Or any similar offences (including attempted or conspiracy to commit) or any offences which replace the above.

6.6 An application will normally be refused if an applicant has a conviction for an offence or similar offences(s) which replace the offences below and the conviction is less than 3 years prior to the date on which the application is determined by the authority:

- S.5 Public Order Act 1986 offence (harassment, alarm or distress).
- S.4 Public Order Act 1986 offence (fear of provocation of violence.)
- S.4A Public Order Act 1986 offence (intentional harassment, alarm or distress).
- Obstruction.
- Criminal damage.
- Or any similar offences (including attempted or conspiracy to commit) or any offences which replace the above.

6.7 A person bound over to keep the peace or be of good behaviour will not normally be granted a licence within the period of the recognisance e.g. where a person is bound over for 6 months, they will not normally be licensed within that 6 month period.

6.8 In the event of a licence being granted, a strict warning both verbally and in writing should be administered.

7. Possession of a weapon

7.1 A conviction for possession of a weapon or any other weapon related offence will raise serious concerns as to the fitness of the applicant to carry the public.

7.2 Depending on the circumstances of the offence, an applicant should be free of conviction for 3 years (or at least 3 years must have passed since the completion of the sentence, whichever is longer), before a licence is granted.

8. Sex and indecency offences

8.1 As licensed drivers often carry unaccompanied and vulnerable passengers, applicants with convictions for sexual offences must be closely scrutinised. Those with convictions for the more serious sexual offences will normally be refused. For other offences, applicants will be expected to show a substantial period (normally at least 15 years) free of conviction for such offences before a licence will be granted.

8.2 Unless there are exceptional circumstances, an application will normally be refused where the applicant has a conviction for an offence such as:

- Rape.
- Assault by penetration.
- Offences involving children or vulnerable adults.
- Or any similar offences (including attempted or conspiracy to commit) which replace the above.

8.3 An application will normally be refused if the applicant has a conviction for an offence listed below and the applicant has not been free of such conviction for at least 15 years.

- Sexual assault.
- Indecent assault.
- Possession of indecent photographs, child pornography etc.
- Exploitation of prostitution.
- Trafficking for sexual exploitation.
- Or any similar offences (including attempted or conspiracy to commit) or any offences which replace the above.

8.4 An application will normally be refused if the applicant has a conviction for an offence listed below and the applicant has not been free of such conviction for at least 5 years.

- Indecent exposure.
- Soliciting (kerb crawling).
- Or any similar offences (including attempted or conspiracy to commit) offences which replace the above.

8.5 In addition to the above the licensing authority will not normally grant a licence to any applicant who is currently on the Sex Offenders Register.

8.6 A licence will not normally be granted if an applicant has more than one conviction for a sex or indecency offence.

9. Dishonesty

9.1 A licensed PHV or taxi driver is expected to be a trustworthy person. They deal with cash transactions and valuable property may be left in their vehicles. The widespread practice of delivering unaccompanied property is indicative of the trust that business people place in licensed drivers. Moreover, it is comparatively easy for a dishonest driver to defraud the public by demanding more than the legal or agreed fare, etc. Overseas visitors can be confused by our currency and may be vulnerable to an unscrupulous driver. For all these reasons, a serious view is taken of any conviction involving dishonesty.

9.2 In general, a minimum period of 3 years free of conviction Offences involving dishonesty include:

- Theft.
- Burglary.
- Fraud.
- Benefit fraud.
- Handling or receiving stolen goods.
- Forgery.
- Conspiracy to defraud.
- Obtaining money or property by deception.
- Other deception.
- Taking a vehicle without consent.
- Or any similar offences (including attempted or conspiracy to commit) or any offences which replace the above.

10. Drugs

- 10.1 A serious view is taken of any drug related offence. The nature and quantity of the drugs, whether for personal use or supply are issues which should be considered.
- 10.2 An application will normally be refused where the applicant has a conviction for an offence related to the **supply of drugs** and has not been free of such conviction for 10 years.
- 10.3 An application will normally be refused where the applicant has more than one conviction for offences related to the **possession of drugs** and has not been free of conviction for 5 years.
- 10.4 An application from an applicant who has an isolated conviction for an offence related to the possession of drugs within the last 3-5 years may be granted a licence, but consideration should be given to the nature and quantity of the drugs.
- 10.5 If there is evidence of persistent drugs use, misuse or dependency, a specialist medical examination (in accordance with DVLA Group 2 medical standards) may be required before the licence is granted. If the applicant was an addict then they would normally be required to show evidence of 5 years free from drug taking after detoxification treatment.

11. Minor and Major Traffic Offences

Minor

- 11.1 Convictions for minor traffic offences e.g. obstruction, waiting in a restricted street, speeding etc. may prevent a person from being granted a hackney carriage or private hire drivers licence if they have received more than 2 motoring convictions within the last 2 years.
- 11.2 The accumulation of 9 or more penalty points will cast grave doubts on the suitability of the applicant and could lead to the refusal of the application.

Major

- 11.3 A serious view will be taken of any conviction for a major traffic offence, this includes:

- Causing death by dangerous driving.

- Dangerous driving.
- Causing death by careless driving whilst under the influence of drink or drugs.
- Causing death by careless or inconsiderate driving.
- Careless and inconsiderate driving.
- Driving under the influence of drink or drugs etc.
- Driving whilst disqualified.
- Using a vehicle without insurance.
- Offences contrary to the taxi licensing legislation.
- Or any similar offences (including attempted or conspiracy to commit) or an offence which replaces the above.

These guidelines make specific provision for certain types of major traffic offences to reflect the seriousness of those convictions. In the case of major traffic offences where no such specific provision is made and paragraph 14 (Disqualification) does not apply, an application will normally be refused unless a period of at least 3 years free from conviction of such offences has elapsed.

12. Driving offences involving the loss of life

12.1 A very serious view is to be taken of any applicant who has been convicted of a driving offence that resulted in the loss of life. A licence will not normally be granted unless the applicant is free of conviction for 7 years if he/she has a conviction for:

- Causing death by dangerous driving.
- Causing death by careless driving whilst under the influence of drink or drugs.
- Or any similar offences (including attempted or conspiracy to commit) or any offences which replace the above.

12.2 Before a licence is granted, an applicant should be free of conviction for 3 years, if he/she has a conviction for:

- Causing death by careless driving.
- Causing death by driving: unlicensed, disqualified or uninsured drivers.
- Or any similar offences (including attempted or conspiracy to commit) or any offences which replace the above.

13. Drink driving/driving under the influence of drugs

13.1 As licensees are professional vocational drivers, a serious view is taken of convictions for driving, or being in charge of a vehicle while under the influence of drink or drugs.

13.2 An isolated incident would not necessarily debar an applicant from proceeding on the restoration of his DVLA driving licence but he should be warned as to the significant risk to his licence status in the event of re-offending and he must comply with the rehabilitation period below.

13.3 More than one conviction for these offences raises significant doubts as to the applicant's fitness to drive the public.

13.4 At least 3 years free of conviction, after the restoration of the driving licence following a drink drive conviction should elapse before an application will be considered. If there is any suggestion that the applicant is alcohol or drug dependent, a satisfactory special medical report must be provided before the application can be allowed to proceed.

14. Disqualification

- 14.1 Where an applicant has been disqualified from driving following a conviction for a major traffic offence and no specific provision is made above regarding the appropriate rehabilitation period, the application will generally be refused unless a period of between 3 and 5 years free from conviction has elapsed from the restoration of the DVLA licence.
- 14.2 Where convictions for a number of minor traffic offences have resulted in the applicant being disqualified from driving for a period of time this will normally be taken as reflecting seriously on the applicant's driving standard. Generally, a period of 12 months free from conviction must have elapsed from the restoration of the DVLA licence.
- 14.3 In "totting-up" cases where disqualification is considered by the court, even if the court does not disqualify (e.g. because of exceptional circumstances) a driver, the Council is likely to refuse a hackney carriage or private hire driver's licence because different criteria apply and an applicant will normally be expected to show a period of 12 months free from conviction from the date the court made its finding of exceptional circumstances justifying the non-disqualification.
- 14.4 Any period of disqualification will lead to the suspension/ revocation of a licence.

15. Insurance offences

- 15.1 A serious view will be taken of convictions of driving or being in charge of a vehicle without insurance. An isolated incident in the past will not necessarily prevent a licence being granted provided he/she has been free of such conviction for 3 years; however a strict warning should be given as to future behaviour. More than one conviction for these offences would normally prevent a licence being granted or renewed.
- 15.2 An operator found guilty of aiding and abetting the driving of passengers for hire and reward whilst without insurance will have his operators' licence revoked immediately and prevented from holding a licence for 3 years.

16. Cautions

- 16.1 Admission of guilt is required before a caution can be issued. Every case will be considered on its own merits including the details and nature of the offence.
- 16.2 If an applicant has received a caution for a traffic offence, given the nature of the offence and the profession of a taxi driver, the applicant may be given a warning as to his/her future conduct.
- 16.3 Cautions for more serious offences could lead to refusal of an application or the suspension or revocation of a licence.

17. Outstanding charges or summonses

- 17.1 If the individual is the subject of an outstanding charge or summons their application can continue to be processed, but the application will need to be reviewed at the conclusion of proceedings.
- 17.2 If the outstanding charge or summons involves a serious offence, then in the interests of public safety the application may be put on hold until proceedings are concluded or the licence may be refused.
- 17.3 A suspension or revocation of the licence of a driver takes effect at the end of the

period of 21 days beginning with the day on which notice is given to the driver. If it appears that the interests of public safety require the suspension or revocation of the licence to have immediate effect, and the notice given to the driver includes a statement that is so and an explanation why, the suspension or revocation takes effect when the notice is given to the driver. [Road Safety Act 2006, s 52, 2A&2B]

18. Licensing offences

18.1 Convictions for offences contrary to taxi legislation such as plying for hire, overcharging and refusing to carry disabled persons would normally prevent a licence being granted or renewed unless the applicant has been free of such convictions for a period of at least 3 years.

19. Licences issued by other licensing authorities

19.1 Applicants who hold a licence with one licensing authority should not automatically assume that their application will be granted by another. Each case will always be decided on its own merits.

20. Summary

20.1 To summarise, a motoring/criminal history in itself may not automatically result in refusal and a current conviction for a serious crime need not bar an applicant permanently from becoming licensed. As the preceding paragraphs indicate, in most cases, an applicant would be expected to remain free from conviction for 3 to 15 years, according to circumstances, before an application can be considered. However, there may be occasions when an application can be allowed before 3 years free from conviction have elapsed.

20.2 Any person who has committed an offence and has to wait before an application is positively considered is more likely to value their licence and act accordingly.

20.3 While it is possible that an applicant may have a number of convictions that, individually, meet the above guidelines, the overall offending history must be considered when assessing an applicant's suitability to be licensed. A series of offences over a period of time is more likely to give cause for concern than an isolated minor conviction. Obviously some discretion can be afforded if an offence disclosed is isolated and there are mitigating circumstances, but the overriding consideration is the protection of the public.

HACKNEY CARRIAGE AND PRIVATE HIRE VEHICLE

COMPLIANCE TESTING STANDARDS

Standards of vehicle test to be applied in addition to the statutory requirements of the MOT test.

Guidance

This document is intended to provide practical guidance to the Council's vehicle testers charged with assessing vehicles being issued with a Certificate of Compliance.

It will also give a general insight into the type of examination the vehicle will be subjected to before it can be issued with a Certificate of Compliance.

It is the responsibility of owners, operators and drivers to ensure that their vehicles comply with the current rules and regulations of the appropriate Road Traffic Act and current Construction and Use Regulations at all times.

Where a vehicle is found not to conform to the requirements of an MOT test and/or the compliance test standards, that vehicle may have its licence suspended until the Council's authorised officers are satisfied that the vehicle is fit to be licensed.

No adaptations, alterations, modifications, additional equipment, optional extras with the exception of tow bars fitted to a professional standard, are to be fitted to the vehicles without the prior approval of the Council.

Any owner wishing to alter or modify the vehicle, including the fitting of extras or alternative parts to those supplied by the manufacturer must seek prior permission from the Council.

Certain modifications may require special inspection by the Council's Authorised Officer or his/her nominee before approval is given. (A fee may be applicable).

When a vehicle presented for compliance test fails on more than six (6) items that vehicle will have to be re-submitted for a full compliance test and the fee charged will be the full compliance test fee. Should a vehicle fail the compliance test on six (6) or less items that vehicle will have to be re-submitted for re-test and the fee will be charged will be the appropriate fee set for a re-test.

**All compliance failure items must be resolved before
a vehicle licence plate can be issued.**

CONTENTS

1. EXTERIOR OF THE VEHICLE
2. BOOT
3. ENGINE COMPARTMENT
4. TYRES AND SPARE WHEELS
5. INTERIOR OF VEHICLE
6. FIRE EXTINGUISHERS AND FIRST AID
7. VEHICLE SIGNAGE
8. UNDERSIDE OF VEHICLE

1. EXTERIOR OF THE VEHICLE

METHOD OF INSPECTION	PRINCIPAL REASON FOR FAILURE
<p>1.1 The exterior of the bodywork, the underside of vehicle is to be in a clean condition so as to facilitate full inspection of these areas</p> <p>1.2 Check operation of all external locks and catches, ensuring all doors can be securely closed locked and easily opened.</p> <p>1.3 Check all doors to ensure that they are aligned properly, will open and close easily and all gaps around doors are reasonably equal. Ensure boot lid opens/closes, and locks correctly and that all hinges and opening mechanisms adequately support the lid when it is in the open position.</p> <p>1.4 Check to ensure all door hinges are in good condition, allowing free movement of door.</p> <p>1.5 Check all wind check positions to ensure that doors are held in place when opened.</p> <p>1.6 Examine the external body panels and structures for any evidence of corrosion, damage, or unsatisfactory repairs.</p> <p>1.7 Examine the external body and paint work for damage, which adversely affects the appearance of the vehicle.</p> <p>1.8 Check nearside and offside door/wing mirrors are fitted in a secure manner and that they function correctly. Ensure aerial is securely fixed.</p> <p>1.9 Ensure front and rear bumpers are in good order (without any damage) and are securely fixed to the vehicle.</p> <p>1.10 Ensure number plates are in good condition and are free of damage, and legible. White reflective at front and yellow reflective at rear.</p> <p>1.11 Examine rubber seals to doors and windows for damage, looseness or absence affecting performance of seals.</p> <p>1.12 Vehicles must be fitted with a key locking fuel cap or an internal means of lock or release.</p> <p>1.13 Reversing lights must be operable when fitted.</p> <p>1.14 All windows to be free of cracks and excessive marking.</p> <p>1.15 No glass, with the exception of a tinted sun-strip along the top of the windscreen, shall be tinted to such an extent as to obscure the view of the inside of the vehicle under normal workshop lighting conditions from a distance of 4 metres.</p>	<p>1. Contamination preventing full or proper inspection.</p> <p>2. Defective external door catches or locks which prevent a door opening or closing properly.</p> <p>3. Poorly fitting doors to the vehicle. Worn locks, hinges or defective boot opening device.</p> <p>4. Door hinges defective.</p> <p>5. Wind checks fail to hold doors in place when opened.</p> <p>6. Corrosion or damage to the vehicle body or structure which adversely affects the appearance and/or safety of the vehicle. Replacement panels fitted that alter the effect of impact Zones. Gaps reasonably unequal around panels.</p> <p>7. Generally poor or damaged body or paintwork, dull, not uniform in colour, and appearance, repairs visible, paint work of poor standard, overspray to any other part of the vehicle.</p> <p>8. Missing or defective mirrors. Aerial not securely fixed.</p> <p>9. Damaged or inadequately secured front or rear bumpers, angled dents and end caps.</p> <p>10. Damage to front or rear number plates.</p> <p>11. Damage or missing, or loose door seals which may cause draught, rainwater ingress unreasonable road noise or trip hazard.</p> <p>12. Vehicle not having a method of securing fuel cap.</p> <p>13. Reverse lights not operable.</p> <p>14. Cracks in windscreen or rear window. Cracks in side windows or excessive marking on any window.</p> <p>15. Glass is tinted to such an extent that the view is obscured inside the vehicle. Front screen must allow 75% of all light through, drivers and front seat passenger windows must allow 70% of all light through.</p>

2. BOOT

METHOD OF INSPECTION	PRINCIPAL REASON FOR FAILURE
<p>2.1 Examine the boot interior for evidence of damage, corrosion or water penetration.</p> <p>2.2 Examine the boot floor to ensure that it is in good condition and offers adequate protection to passenger's luggage stored in boot.</p> <p>2.3 Examine interior of boot to ensure it is clean and free of dirt, dust, grease, litter etc.</p> <p>2.4 Check boot for presence of any containers of any flammable or corrosive material (e.g. oil, petrol or diesel)</p> <p>2.5 Ensure that boot can be secured by a locking mechanism.</p>	<p>1. Damage to the floor of the boot, inner wing panels or lid.</p> <p>2. Excessive wear, damage or staining to the boot floor.</p> <p>3. Accumulation of dirt, grease, dust, litters or rubbish in the boot which could soil or damage luggage stored within.</p> <p>4. Containers for the storage of petrol, diesel or any corrosive material shall not be carried in the vehicle.</p> <p>Note: A five litre bottle of engine oil and water will be permitted.</p>

3. ENGINE COMPARTMENT

METHOD OF INSPECTION	PRINCIPAL REASON FOR FAILURE
<p>3.1 Carry out visual inspection of engine compartment for signs of fuel, oil or water leaks.</p> <p>3.2 check to ensure that the battery is properly secured in its correct position.</p> <p>3.3 Examine all plastic/rubber or metal hoses for signs of deterioration or damage.</p> <p>3.4 Check drive belt for correct adjustment and for signs of deterioration or damage.</p> <p>3.5 Check security of radiator and check hoses for leaks.</p> <p>3.6 Examine engine/transmission mounts for signs of deterioration or wear.</p> <p>3.7 Check clutch mechanisms for correct operation.</p> <p>3.8 Check operation of bonnet releases/s catches.</p> <p>3.9 Run engine to normal operational temperature to ensure the engine is not breathing out any excess fumes.</p> <p>3.10 Fuel cut off switch to be operable and present where known to be fitted as standard.</p> <p>3.11 All LPG powered vehicles must have an installation certificate and an annual service certificate</p>	<ol style="list-style-type: none"> 1. Excessive oil, fuel or water leaks. 2. Battery not adequately secured. 3. Worn or deteriorated hoses or pipes. 4. Incorrectly adjusted or damaged drive belt. 5. Leaking or insecure radiator. 6. Insecure or deteriorated engine/transmission mountings. 7. Leakage of fluid or mechanical wear in the clutch mechanisms. 8. Defective bonnet release catch or mechanisms. 9. Engine breathing excess fumes. 10. Switch inoperable or removed. 11. No available installation certificate or annual service certificate. All such cases should be reported to the Licensing Team as soon as possible.

4. TYRES AND SPARE WHEEL	
METHOD OF INSPECTION	PRINCIPAL REASON FOR FAILURE
<p>4.1 Ensure that spare tyre is of same size and construction as those fitted to the road wheels or manufacturers supplied space saver wheel. Vehicles manufactured without a spare wheel/spacer saver are allowed a tyre weld.</p> <p>4.2 Examine tyres for signs of damage or excessive uneven wear ensure spare tyre complies with all legal requirements for tyres when fitted to the vehicle.</p> <p>4.3 Check to ensure all tyres are inflated to correct pressure for the vehicle.</p> <p>4.4 Examine the wheel brace and jack provided to ensure they are in good working order.</p> <p>4.5 Check to ensure the spare wheel fixing bracket (or similar device) will hold spare securely in position.</p> <p>4.6 Check any spare wheel rim for any signs of distortion or damage.</p> <p>4.7 All tyres to have a minimum tread depth of 1.6mm across 75% centre tread width with the remaining 25% to have tread pattern showing, including spare.</p> <p>4.8 If vehicle fitted with wheel trims as standard for that type of vehicle all must be present and in good repair.</p>	<p>1. A spare wheel not provided with the vehicle. A tyre that is of a different size or construction or a non-manufactured supplied space saver wheel. No tyre weld provided</p> <p>2. Damaged, worn, sub standard or otherwise illegal tyre.</p> <p>3. Under inflated tyre.</p> <p>4. Failure to provide a suitable jack/wheel brace.</p> <p>5. Spare wheel and tools not secured properly.</p> <p>6. A seriously damaged or distorted rim which impairs the ability to hold the tyre.</p> <p>7. Tyres not showing the required tread depth.</p> <p>8. Wheel trims missing, badly scuffed or damaged.</p> <p>NOTE:</p> <p>4(a) A mix of steel and cord radials will not be accepted.</p> <p>4(b) Re-cut tyres are not accepted.</p> <p>4(c) Remould tyres will not be acceptable.</p>

5. INTERIOR OF THE VEHICLE

METHOD OF INSPECTION	PRINCIPAL REASON FOR FAILURE
5.1 Examine all floor and upholstery inside the vehicle for any damage, accumulation of dirt, dust, litter, general debris, staining, or excessive wear. Examine roof lining for excessive staining and any damage.	1. A vehicle which is in a dirty condition with accumulations of dust, dirt, litter, debris, damage or staining (including roof lining).
5.2 Remove any mats from floor and examine carpeting for signs of leakage of water into the vehicle.	2. Evidence of leakage of water into vehicle.
5.3 Examine any mats to ensure they are not worn, damaged or a tripping hazard.	3. Upholstery including trims and panels which are damaged, excessively worn or holed/torn.
5.4 Sit in each of the seats within the vehicle to ensure that all seat cushions are in good condition and offer proper support.	4. Seat cushions or back rests which are in poor condition and/or offer poor support.
5.5 Examine all seats to ensure they are properly secured to the vehicle including fixed seat cushions.	5. Seats which are not adequately secured to the vehicle.
5.6 Check operation of interior lights, checking both manual and door operated switches (Note: all doors to have switches fitted if fitted as standard by manufacturer).	6. Faulty interior light fitting/s or switch/es.
5.7 Examine rear view mirrors to ensure they are securely fixed.	7. Loose, cracked, damaged or missing rear mirror or one that impairs vision.
5.8 Check operation of the heater and demisters to ensure they work correctly.	8. Defective heater or demisters.
5.9 Check operation of clutch and also condition of pedal rubbers.	9. Defective clutch operation, worn or missing pedal rubbers.
5.10 Check operation of rear screen heater to ensure it is functioning correctly.	10. Defective rear screen heater.
5.11 Check operation of all window winders (or electric buttons) and door locks ensuring they open and close easily.	11. Window winders (or electric buttons) that do not allow windows to be lowered/raised easily. Defective window locks or associated fittings.
5.12 Check the operation of all door release catches including motion door locks to ensure that doors can be opened easily from within the vehicle.	12. Defective interior door release catches. Defective motion locks, motion locks fitted with override. Warning lamps inoperative, warning labels damaged or defaced.
5.13 Ensure childproof locks function correctly where fitted.	13. Defective childproof locks.
5.14 Check all door handles, and grab rails for condition and security. Ensure childproof protection covers are in place and free of damage and held in place securely.	14. Door handles, interior trims, mouldings, damaged, worn or not secured properly.
5.15 Check for unpleasant odours within the vehicle.	15. Unacceptable smells.
5.16 If metal grill is fitted ensure it has no sharp edges or exposed parts that may lead to injury of passengers or driver, ensure grill is firmly secured. (Metal grill must not prevent operation of privacy partition).	16. Loose or incorrectly fitted grill or exposed parts that may cause injury. Privacy partition obstructed.
5.17 Check that a luggage grill/cover is fitted to estate cars.	17. Luggage grill/cover not fitted.

<p>5.18 Check that intercom systems (where fitted) are capable of being switched off within passenger compartment and that there are signs clearly visible explaining their use and how to switch them off. Check that a light is visible when intercom is on.</p> <p>5.19 Check condition of all electrical wiring to ensure it's routed correctly and poses no risk or hazard to passengers.</p> <p>5.20 CCTV shall be firmly affixed where fitted.</p> <p>5.21 Ensure gaiter around lever is present and not split.</p> <p>5.22 Fittings</p> <p>All fittings shall be properly maintained and in good working order. Fittings include clocks, interior lights, sun blinds, door surrounds, grab handles, other equipment provided for passenger comfort and any equipment in on or forming part of the vehicle including wheelchair ramps and securing fittings where the vehicle is to carry wheelchair bound passengers.</p> <p>5.23 Hand brake working correctly.</p> <p>5.24 Radio, PDA, Sat Navs, Mobiles, must not block the driver's 'A' zone view through the windscreen. The 'A' zone is approximately the portion of the windscreen that you can see through if you were to draw two lines upwards vertically from the inner edges of the steering wheel.</p> <p>5.25 All seatbelts should be checked and have no cuts, or fraying of the belt, not be twisted, and engage and disengage easily in the fixed buckle and lock when snatched simulating emergency braking.</p> <p><u>Hackney Carriage Only</u></p> <p>5.26 Check that a Taxi Meter is installed into the vehicle and connected to the roof sign. The meter should be sealed with either a 'Green plug style' seal or a numbered lead seal.</p>	<p>18. Intercom system not clearly marked. No means of passenger isolating system easily. Warning light not working.</p> <p>19. Wiring not routed correctly, unsecure, damaged, and poses a hazard or risk to passengers.</p> <p>20. Loose camera or screen fitted.</p> <p>21. Split or missing gaiter can allow debris to fall into gear linkage.</p> <p>22. any item not deemed to be in working order.</p> <p>23. Apply handbrake and push vehicle if vehicle moves its not serviceable.</p> <p>24. Any item blocking the 'A' zone that cannot easily be removed at the time of inspection constitutes a fail until a permanent solution is sought.</p> <p>25. Any cuts or fraying of belt, any twisted belts that do not move freely or engage and disengage easily in the fixed buckle and lock when snatched simulating emergency braking.</p> <p>26. Any Hackney Carriage vehicle without a meter. Any meter that has the seal missing, damaged, defaced, in the case of the 'plug style' seal is not green in colour and in the case of the lead seal, has no number on the lead tag. All numbered tags must be copied onto inspection certification sheets.</p> <p>NOTES:</p> <p>5.1 Vehicles presented in a dirty untidy condition will not be tested.</p> <p>5.2 Where interior trims or roof lining have one rip or tear of not more than 75mm a good quality stitched repair is acceptable (patches are not allowed).</p> <p>5.4 Patching is not acceptable on any interior upholstery. Advice may be given that a roof lining will be required to be renewed at the next test.</p> <p>5.16 If a glass partition is fitted this must be safety glass or plastic.</p> <p>5.17 All trims, mouldings, door handles, grab handles to be free of damage.</p> <p>5.19 All electrical wiring to be in good order and securely routed. When going through panels the wiring must be protected by rubber grommets.</p>
---	---

6. FIRE EXTINGUISHERS & FIRST AID

METHOD OF INSPECTION	PRINCIPAL REASON FOR FAILURE
<p>EXTINGUISHER</p> <p>6.1 Check to ensure that the fire extinguisher is a 1-litre rated AFFF (aqueous film foam) type or powder.</p> <p>6.2 Ensure that the vehicle registration number is clearly marked on the identification tag attached to the extinguisher.</p> <p>6.3 Ensure that seal is in place and has not been tampered with and is intact.</p> <p>6.4 Visibly check extinguisher for signs of damage.</p> <p>6.5 Extinguishers to be affixed within the driving compartment or in boot compartment in readily accessible position with a security TAG showing registration of vehicle.</p> <p>FIRST AID</p> <p>6.6 A secure and clearly identifiable first aid container must be provided, to contain not less than:</p> <ul style="list-style-type: none"> • 10 x medifresh antiseptic wipes or equivalent • 1 x 7.5cm bandage • 2 x triangular bandages • 24 x assorted plasters • 3 x large ambulance dressings • 2 x eye pads and elastic to secure • 12 x assorted safety pins • 1 x pair scissors • 2 x pair's disposable gloves. 	<ol style="list-style-type: none"> 1. Fire extinguisher not of approved type or rating 2. Vehicle registration number is not clearly attached to identification tag on extinguisher. 3. Approved seal is not in place, or is damaged. 4. Visible signs of damage which would impair its use. 5. Anything other than that described at 6.5 6. Anything other than that described at 6.6.

7. VEHICLE SIGNAGE	
HACKNEY CARRIAGE ONLY	
METHOD OF INSPECTION	PRINCIPAL REASON FOR FAILURE
<p>7.1 Roof signs to be white in colour and securely fitted to the vehicle. The minimum height of the roof sign must not be less than 127mm. The minimum length of the roof sign must not be less than 406mm.</p> <p>7.2 Check that signage is displayed on the roof with the work 'TAXI' on the front and 'FENLAND DISTRICT COUNCIL' on the back together with the carriage licence number on the back (except in the case of London style cabs).</p> <p>7.3 Check that the sign shall be capable of being illuminated internally (connected to the taxi meter operation) in such a manner that the words 'TAXI' and 'FENLAND DISTRICT COUNCIL' together with the carriage licence number, are illuminated at all times when the vehicle is plying for hire, but not otherwise.</p> <p>The small 'for hire' sign that used to be on the dash board and illuminated manually by the driver must be removed.</p> <p>7.4 Check all wording and numbering on the roof sign to be in black lettering and the word 'TAXI' displayed at the front of the roof sign shall not be less than 125mm in height.</p>	<p>1. Roof sign is not white in colour or securely fitted to the vehicle. The roof sign does not comply with the specified sizes.</p> <p>2. The specified wording is not displayed on the roof sign.</p> <p>3. The roof sign is not capable of being illuminated internally, through the operation of the taxi meter.</p> <p>The small 'for hire' sign is still in the vehicle.</p> <p>4. Wording is not in black lettering or is not of specified size. Letters are damaged, missing or defaced.</p>
PRIVATE HIRE ONLY	
METHOD OF INSPECTION	PRINCIPAL REASON FOR FAILURE
<p>7.5 The private hire vehicle shall not have a roof mounted sign of any kind.</p> <p>7.6 The private hire vehicle shall not display any sign, which consists of or includes the work 'TAXI' or 'CAB' whether singular or plural, or 'HIRE' or any word of a similar meaning or appearance to any of those words, whether alone or as part of another word. The only exception for use of the word 'HIRE' displayed on a private hire vehicle is when the word is used in conjunction with the word 'PRIVATE' to form the word 'PRIVATE HIRE'.</p> <p>7.7 A sign must be displayed on the front doors of the vehicle specifying the operator name, with a telephone number for bookings, with the wording 'PRE-BOOKED ONLY' with letters in black no smaller than 60mm in height on a yellow background with a black border. The sign must be clearly visible in a prominent position on the sides of the vehicle.</p> <p>Removable signs e.g. magnetic will not be permitted.</p>	<p>5. The private hire vehicle has a roof mounted sign.</p> <p>6. The private hire vehicle has the wording 'TAXI' or 'CAB' or words of a similar meaning.</p> <p>7. There is no signage, not prominently displayed on each side of the vehicle. The signage is not clearly visible. The writing for the signage is smaller than 60mm in height. The sign is not yellow with a black border line around the sign with black writing. The sign is removable e.g. magnetic etc.</p> <div style="text-align: center;">  <p>FENLAND LOGO</p> <p>Pre-Booked Only</p> <p>Insurance invalid unless booked with operator</p> </div>

8. UNDERSIDE OF VEHICLE

METHOD OF INSPECTION	PRINCIPAL REASON FOR FAILURE
<p>8.1 Check to ensure the vehicle is free of any leakage of Water, Fuel and Oil.</p> <p>8.2 Check for security/wear in any drive shafts.</p> <p>8.3 Check for excess corrosion/damage.</p> <p>8.4 Check for wear of any engine or transmission mounting that does not fall within the scope of the MOT tester's manual.</p> <p>8.5 Ball joint rubbers to be free of damage.</p> <p>8.6 Damaged, torn or unsecure inner/outer drive shaft gaiters.</p>	<p>1. The vehicle has an excessive fuel, oil or water leakage. No oil leaks allowed that are continuous or that cause a puddle or spread of 75mm in a five minute time period examined while the engine is running. Oil includes power steering, fluid, brake fluid, clutch fluid, gearbox oil, automatic transmission fluid, suspension, petrol, and diesel but excludes water.</p> <p>2. Unsecure or worn drive shaft components or mounting.</p> <p>3. Evidence of excess corrosion/damage to underside of the vehicle.</p> <p>4. Worn or damaged mountings.</p> <p>5. Missing, torn or damaged mountings.</p> <p>6. Release of lubrication from joint.</p>
	<p>Notes: When a vehicle fail on fuel, oil, water leaks, on it's re-test it will be left running for no less than five minutes prior to inspection.</p>

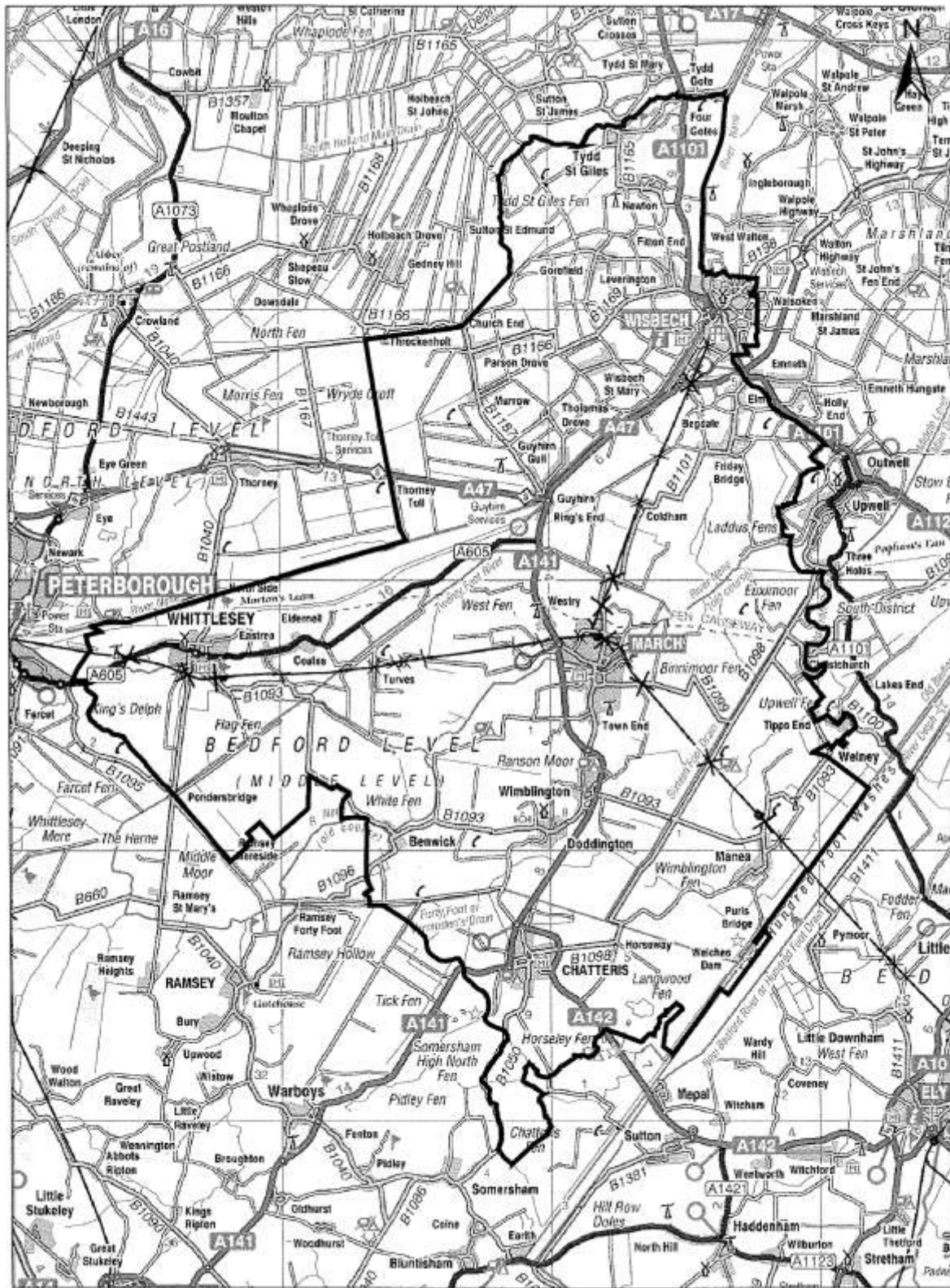

This map is reproduced from the Ordnance Survey map by Fenland District Council with the permission of the Controller of Her Majesty's Stationery Office. © Crown Copyright. Unauthorised reproduction infringes Crown Copyright and may lead to prosecution or civil proceedings. Licence No 10023778, 2009

Fenland District

Scale = 1:178,739

